



MILLER & KREISEL®



[www.mksound.com](http://www.mksound.com)

M&K Sound, the logo, Miller & Kreisel logo and Tripole are trademarks of M&K Sound A/S. All trademarks are registered in some jurisdictions. All rights reserved.

***The Choice of Professionals®***

2023 - ver. 1.0



MILLER & KREISEL®



# Miller & Kreisel The Choice of Professionals®

For more than fifty years, M&K Sound has been held in the highest regard by film and music professionals, the audio press and residential customers seeking the finest loudspeakers for use in home cinemas and living rooms.

Because all our loudspeakers exhibit a signature of audio neutrality, exquisite detail and transparency from any source, they have rightfully earned their designation as “The Choice of Professionals”. We constantly enhance the performance of our product range through extensive research and development, without ever sacrificing our loudspeakers’ inherent DNA and industry-defining characteristics.

Many of the greatest film and music recordings of all time have been mixed, mastered and monitored on M&K Sound’s audio systems. Revered artists, musicians, movie directors and recording engineers in hundreds of studios and post-production facilities around the world choose M&K Sound. Star Wars: Episodes I – III, and Peter Jackson’s King Kong and The Lord of the Rings Trilogy are among the cinematic classics that have been mixed and mastered on complete Miller & Kreisel sound systems.

Building on a truly unique heritage and strong market presence that transcends the traditional boundaries between professional and consumer audio, M&K pledges to offer performance, reliability, and value for money that is second to none.



## Contents

IW Series . . . . .	8-15
CI Series. . . . .	.16-17
300 Series . . . . .	.18-19
150 Series . . . . .	.22-23
950 Series . . . . .	.24-25
750 Series . . . . .	.26-27
D Series . . . . .	.30-31
M Series . . . . .	.32-35
PRO Series . . . . .	.38-39
X+ Series . . . . .	.44-47
V+ Series . . . . .	.48-49
Movie 5.1 System . . . . .	.52-53
Rear Panel Dimensions. . . . .	.56-57





“

**It is both exciting and a privilege to represent M&K Sound, a brand that has such a rich heritage in both the music and movie industries”**

*Richard Vaughn  
Planetworld*







## IW300 In-Wall Speaker

The IW300 features the same proprietary drivers and crossover as the famed Miller & Kreisel S300 Series. The unique design allows critical audio professionals to hear exactly what's going on in the mix and listen for hours with no hint of fatigue. This is the ultimate choice for the music and cinema enthusiast seeking the finest in-wall speakers available



Impedance.....	4 Ohm
Recommended Amplifier Power.....	25 – 500W
Bass/Midrange.....	2 x 6.5" Glassfibre
High Frequency Driver.....	3 x 1" Soft fabric dome
Frequency Response.....	80 Hz – 22 kHz, ±3dB
Sensitivity.....	93 dB, 2.83V/1m
Grille Dimensions (HxW).....	16.92 x 13.58", 430 x 345 mm
Baffle Dimensions (HxW).....	16.65 x 13.30", 423 x 338 mm
Wall Cutout (HxW).....	15.78 x 12.44", 401 x 316 mm
Mounting Depth.....	4.73", 120 mm
Weight.....	22.0 lbs / 10 kg
Grill Finish.....	White metal, paintable

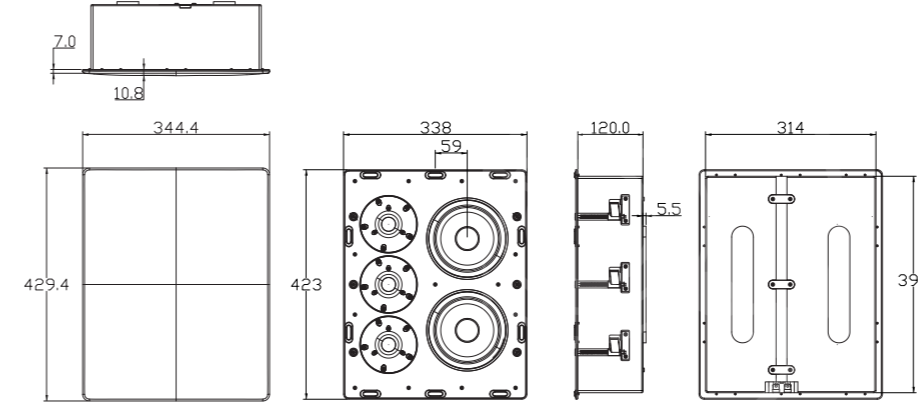

## IW150 In-Wall Speaker **Acoustic Upgrade**

This award winning design is the in-wall equivalent of Miller & Kreisel's S150 Series used on a daily basis as the preferred monitoring tool in hundreds of professional film and music recording studios around the world and in thousands of serious home entertainment systems. Can there be any better choice than the speakers on which your favorite movies and music were actually created?



Impedance.....	4 Ohm
Recommended Amplifier Power.....	25 – 400W
Bass/Midrange.....	2 x 5.25" Glassfibre
High Frequency Driver.....	3 x 1.1" Soft fabric dome
Frequency Response.....	80 Hz – 20 kHz, ±3dB
Sensitivity.....	90 dB, 2.83V/1m
Grille Dimensions (HxW).....	14.17 x 12.51", 360 x 318 mm
Baffle Dimensions (HxW).....	13.93 x 12.24", 354 x 311 mm
Wall Cutout (HxW).....	13.03 x 11.33", 331 x 288 mm
Mounting Depth.....	3.74", 95 mm
Weight.....	18.8 lbs / 8,5 kg
Grill Finish.....	White metal, paintable

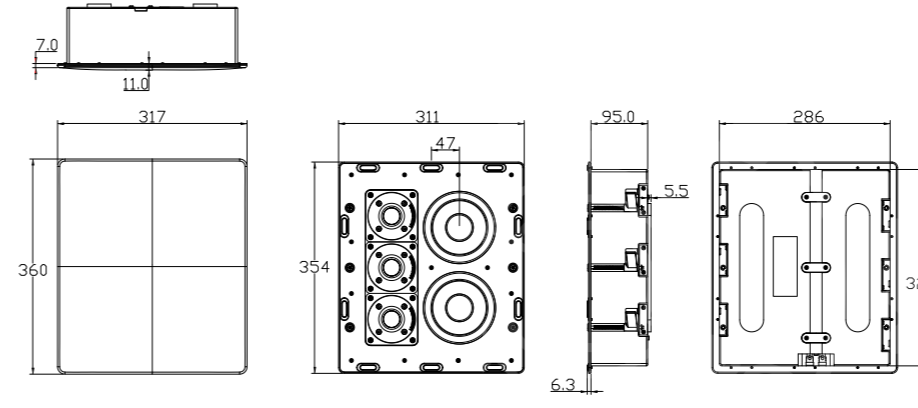

## IW950 In-Wall Speaker **Acoustic Upgrade**

The IW950 incorporates proprietary Miller & Kreisel drive units and technologies drawn from the classic 950 Series. Stable, smooth installation and the same sophisticated design philosophy developed for all Miller & Kreisel speakers ensures even sound throughout any room with superior imaging, whether mounted in-wall or in-ceiling.



Impedance.....	4 Ohm
Recommended Amplifier Power.....	25 – 400W
Bass/Midrange.....	2 x 5.25" Glassfibre
High Frequency Driver.....	1.1" Soft fabric dome
Frequency Response.....	80 Hz – 20 kHz, ±3dB
Sensitivity.....	90 dB, 2.83V/1m
Grille Dimensions (HxW).....	19.52 x 9.44", 496 x 240 mm
Baffle Dimensions (HxW).....	19.25 x 9.21", 489 x 234 mm
Wall Cutout (HxW).....	18.38 x 8.34", 467 x 212 mm
Mounting Depth.....	3.74", 95 mm
Weight.....	17.7lbs / 8 kg
Grill Finish.....	White metal, paintable

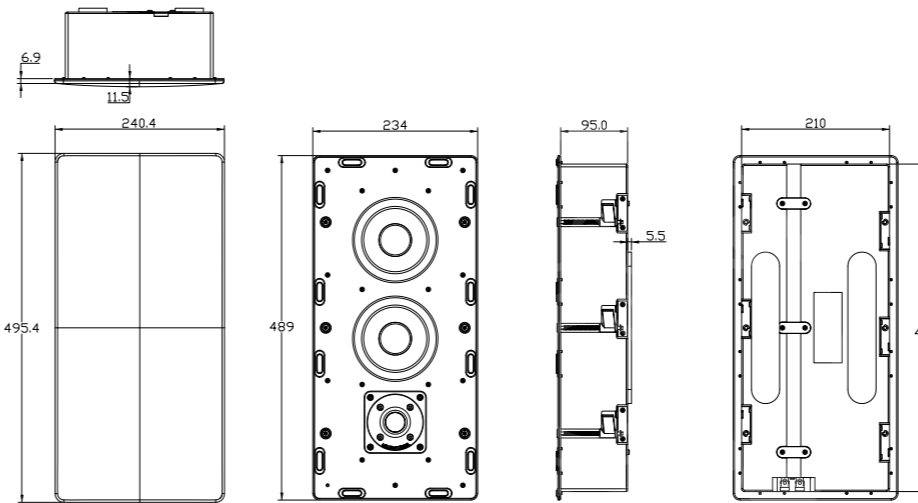

# IW SERIES





## IW95 In-Wall Speaker **Acoustic Upgrade**

As a direct descendant of Miller & Kreisel's standard-setting professional studio monitors, the highly versatile IW95 is built on a thick rock-solid steel baffle and uses robust steel mounting brackets. The universal IW95 is suitable for any complex installation and delivers a seamless, holographic, three-dimensional listening experience.

Impedance .....	4 Ohm
Recommended Amplifier Power .....	25 – 300W
Bass/Midrange .....	6.5" Polypropylene
High Frequency Driver .....	1" Soft fabric dome
Frequency Response .....	80 Hz – 20 kHz, ±3dB
Sensitivity .....	91 dB, 2.83V/1m
Grille Dimensions (HxW) .....	12.40 x 9.33", 315 x 237 mm
Baffle Dimensions (HxW) .....	12.16 x 9.13", 309 x 232 mm
Wall Cutout (HxW) .....	10.75 x 7.44", 273 x 189 mm
Mounting Depth .....	.367", 93 mm
Weight .....	10.0 lbs / 4.6 kg
Grill Finish .....	White metal, paintable

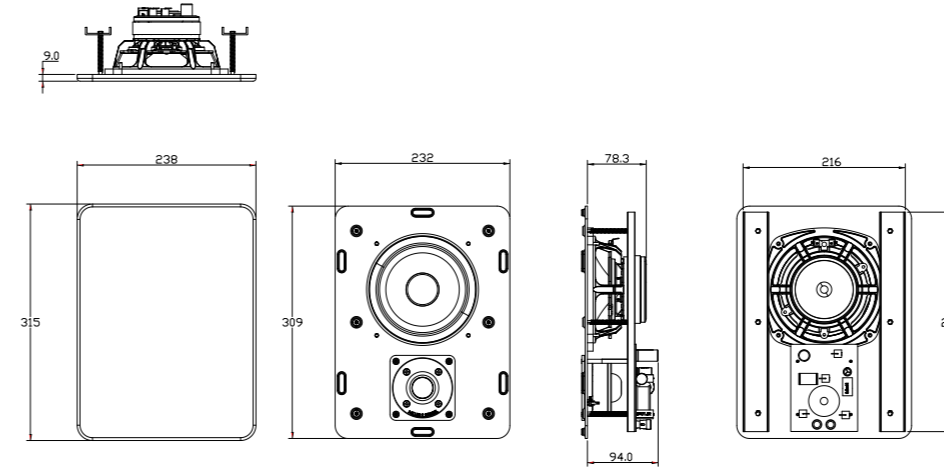

## IW85 In-Wall Speaker **Acoustic Upgrade**

Experience full-range, designer-friendly sound to rival many "audiophile" standalone speakers in a compact package that integrates beautifully into walls or ceilings. The versatile IW85 is superb in two-channel or surround applications and can be combined with any Miller & Kreisel speakers for a seamless sonic timbre match.

Impedance .....	4 Ohm
Recommended Amplifier Power .....	25 – 200W
Bass/Midrange .....	5.25" Polypropylene
High Frequency Driver .....	1" Soft fabric dome
Frequency Response .....	85 Hz – 20 kHz, ±3dB
Sensitivity .....	88 dB, 2.83V/1m
Grille Dimensions (HxW) .....	10.62 x 6.88", 270 x 175 mm
Baffle Dimensions (HxW) .....	10.39 x 6.65", 264 x 169 mm
Wall Cutout .....	9.4" x 6", 239 x 152 mm
Mounting Depth .....	.367", 93 mm
Weight .....	9.0 lbs / 4.1 kg
Grill Finish .....	White metal, paintable

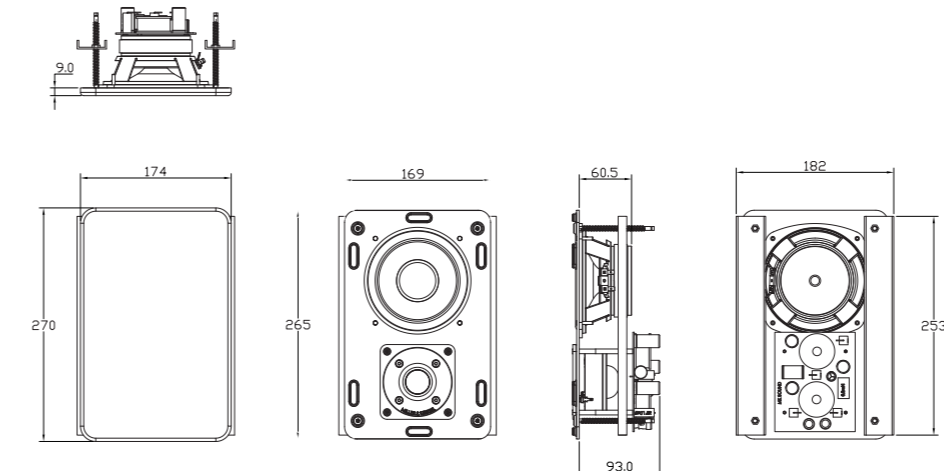

## IW5 In-Wall Speaker

Designed with the same richly detailed sound as the Miller & Kreisel M Series. The IW5 is supplied with a slim round grille making it the optimal choice as an In-ceiling solution. The ultra compact IW5 is the invisible flush-mount speaker that delivers consistent sound quality across large spaces or multiple zones.

Impedance .....	4 Ohm
Recommended Amplifier Power .....	25 – 125W
Bass/Midrange .....	4" Polymer coated texture taper
High Frequency Driver .....	1" Soft fabric dome
Frequency Response .....	100 Hz – 20 kHz, ±3dB
Sensitivity .....	85 dB, 2.83V/1m
Grille Dimensions, round (Ø) .....	8.81", 224 mm
Baffle Dimensions diagonal .....	8.66" / 220 mm
Baffle Dimensions (HxW) .....	7.28 x 5.66", 185 x 144 mm
Wall Cutout (HxW) .....	6.45 x 4.88", 164 x 124 mm
Mounting Depth .....	4.05", 103 mm
Weight .....	5.3 lbs / 2.4 kg
Grill Finish .....	White metal, paintable

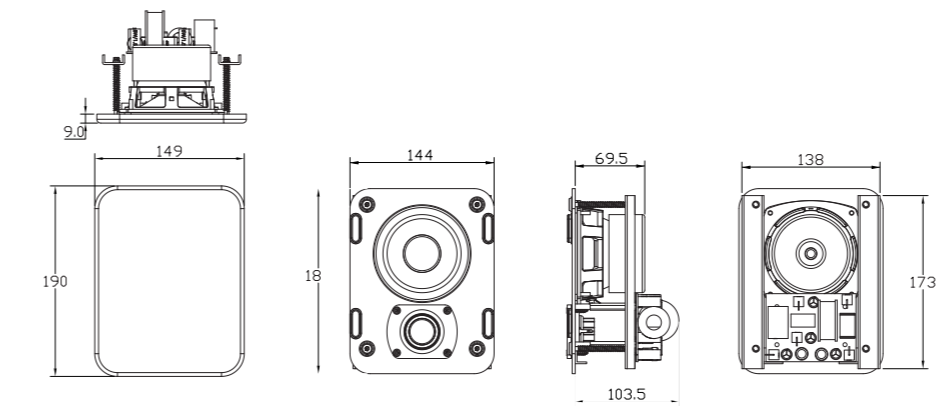

IW  
S  
E  
R  
I  
E  
S





## IW150T Tripole® In-Wall Speaker

The IW150T is the in-wall equivalent of the famous S150T Tripole® surround speaker. Incorporating the exact same drivers and crossover technology as the S150T sealed cabinet speaker, the IW150T delivers uncompromising performance from a less obtrusive form factor. Modern installations and new surround formats such as Dolby Atmos and DTS:X are incorporating more and more surround channels. In-wall (and in-ceiling) installations allow you to expand to take full advantage of these new formats without the clutter of visible wires or speakers. The introduction of the IW150T Tripole® Speaker means you can have the same M&K 150 Series acoustic performance from a completely invisible installation.



Nominal System Impedance	4 Ohm
Frequency Response	60Hz-20kHz, +/-3dB
Frequency Roll Off	55Hz -6dB
Crossover Frequency	1.5KHz
Front Tweeter	1.1" Dome, Coated Silk Dome / Low Compression
Front Woofer	5.25", Coated Glass Fiber
Side Drivers	2 x 2.35", Polymer Coated Textured Paper
Power Handling	100W Long Term IEC-268-5 (Cycled Input 80-20kHz)
Power Handling	50W rated IEC-268-5 (Constant Input 80-20kHz)
Recommended Amp Power	25-200W
Sensitivity	85dB verage SPL 2.83V / 1M (On-Axis 200-10kHz)
System Princip	Sealed Enclosure
Connection Terminal	Gold Plating, Spring Loaded Banana
Finish	Powder Coat Black Fascia, White Metal Grill, Paintable
Dimensions, H x W x D	354mm x 311mm x 95mm
Cutout	331mm x 288mm
Weight	6.8 kg / 14.99 lbs

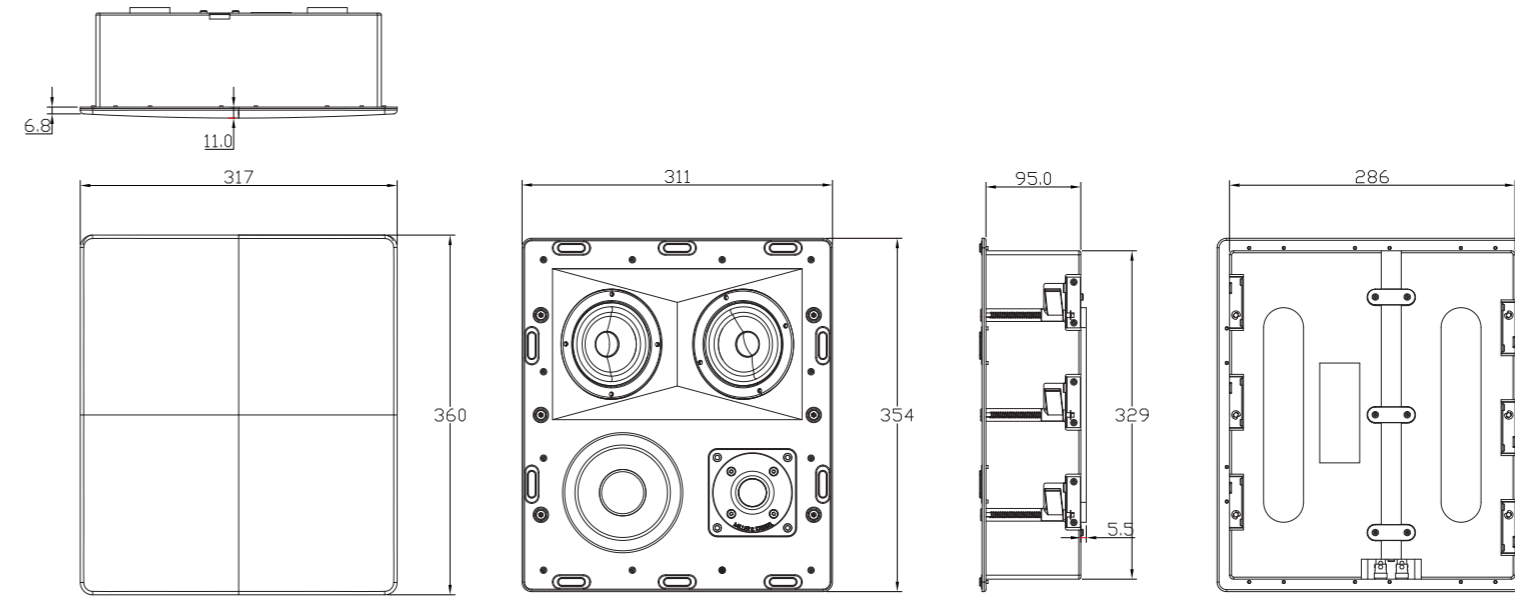

## IW150A New Product In-Wall/In-Ceiling Speaker

The IW150A is a versatile in-wall/in-ceiling speaker designed for the ultimate home theater experience. Targeted primarily as a Dolby Atmos-friendly in-ceiling model, the speaker can also be used for other in-wall cinema or multi-room applications. Its single 15-degree angle-fixed tweeter makes the IW150A ideal for effects-based sound in multi-speaker setups.

The debut of this new 150 Series loudspeaker means that, along with the IW28S subwoofer, M&K Sound offers a complete and seamless in-wall/in-ceiling solution for reference-grade home cinemas. The IW150A's wide dispersion characteristics and versatility mean it can be placed in any ceiling- or wall-based orientation or location.



Nominal System Impedance	4 ohm, (Z-min 3.4 ohm)
Frequency Response	80-20KHz, (average response in room +/- 3 dB)
Frequency Roll Off	80 Hz, (-9 dB 80 Hz near field)
Crossover Frequency	2.0K Hz, "Phase focused" (2nd order)
Tweeter	1 x 1,1" Dome. Coated silk dome / Low compression
Tweeter Angle	15.0°, angle fixed
Woofer	2 x 5.25", coated glass fibre
Woofer Angle	5.7°, angle fixed
Power Handling	180 watt. Long term IEC-268-5 (cycled input 77-20K Hz)
Power Handling	90 watt. Rated IEC-268-5 (constant input 77-20K Hz)
Recommended Amp Power	25-400 watt. Recommended amp power Min / Max
Sensitivity	90 dB. Average SPL 2.83 volt / 1mtr (on axis 200-10K Hz)
Max SPL Continued	110 dB. Sinewave 100-8000 Hz / THD < 10%
Max SPL Peak	116 dB, Sinewave 100-8000 Hz / THD < 10%
System Principle	Sealed enclosure
Connection	Terminal Gold Plating, Push terminal 4mm cable
Finish	Paint, Black cabinet. Metal white grille
Cutout	H x W, 13.03 x 11.33 inch / 331 x 288 mm
Cabinet dimensions	H x W, 12.95 x 11.25 inch / 329 x 286 mm
Cabinet depth	D, 3.74 inch / 95 mm
Dimensions Grille	H x W x D, 14.17 x 12.48 inch / 360 x 317 mm
Weight	Netto, 21.6 lbs / 9.8 kg

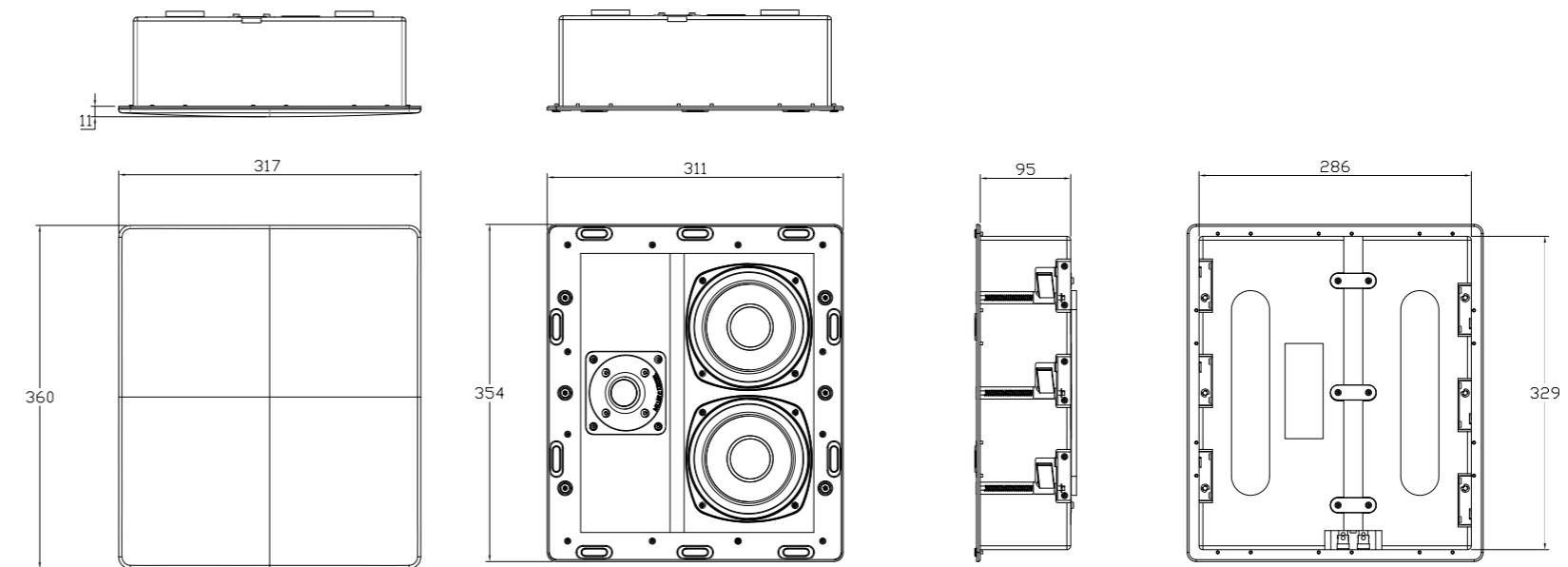

# IW SERIES





## IC95 In-Wall / In-Ceiling Loudspeaker

The new compact IC95 integrated loudspeaker system is based on M&K Sound's well-proven and proprietary 6.5-inch mid-woofer, also used in the MPS1620P studio monitor.

The mid-woofer in the IC95 is a long-time accepted key component of the M&K signature sound.

The loudspeaker sports a newly developed axial-mounted 1-inch soft fabric dome tweeter, designed with a swivel function, both to angle and optimize on-axis response to the listening position.

Nominal system impedance	4 ohm (Z-min 3.4 ohm)
Frequency response with can	70-20Khz (-12dB at 70 Hz)
Frequency response without can	50-20 KHz (-12 dB at 50 Hz)
Crossover frequency	.45Khz "Phase focused" (2nd order)
Tweeter	1" Dome. Coated silk dome / with swivel function
Woofer	6.5". Mineral filled polypropylene
Power handling	150 watt. Long term IEC-268-5 (cycled input 100-20Khz)
Power handling	75 watt. Rated IEC-268-5 (constant input 100-20Khz)
Recommended amp power	25-300 watt
Sensitivity	90 dB. Average SPL 2.83 Volt / 1mtr (on axis 200-10KHz)
System princip	In wall / Sealed enclosure
Connection	Terminal gold plating. Push terminals 4mm cable
Accessories	Cut out template / Optional can available
Welcome Card	Included in packing
Speaker OD Diameter	9.64 inch / 245 mm
Grill OD Diameter	9.74 inch / 248 mm
Cut out Diameter	8.5 inch / 218 mm
Depth with can	8.3 inch / 212 mm
Depth without can	3.85 inch / 98 mm
Weight W/WO can, Netto	9.2 / 5.7 lbs / 4.2 / 2.6 kg
Grill Finish	White metal, paintable

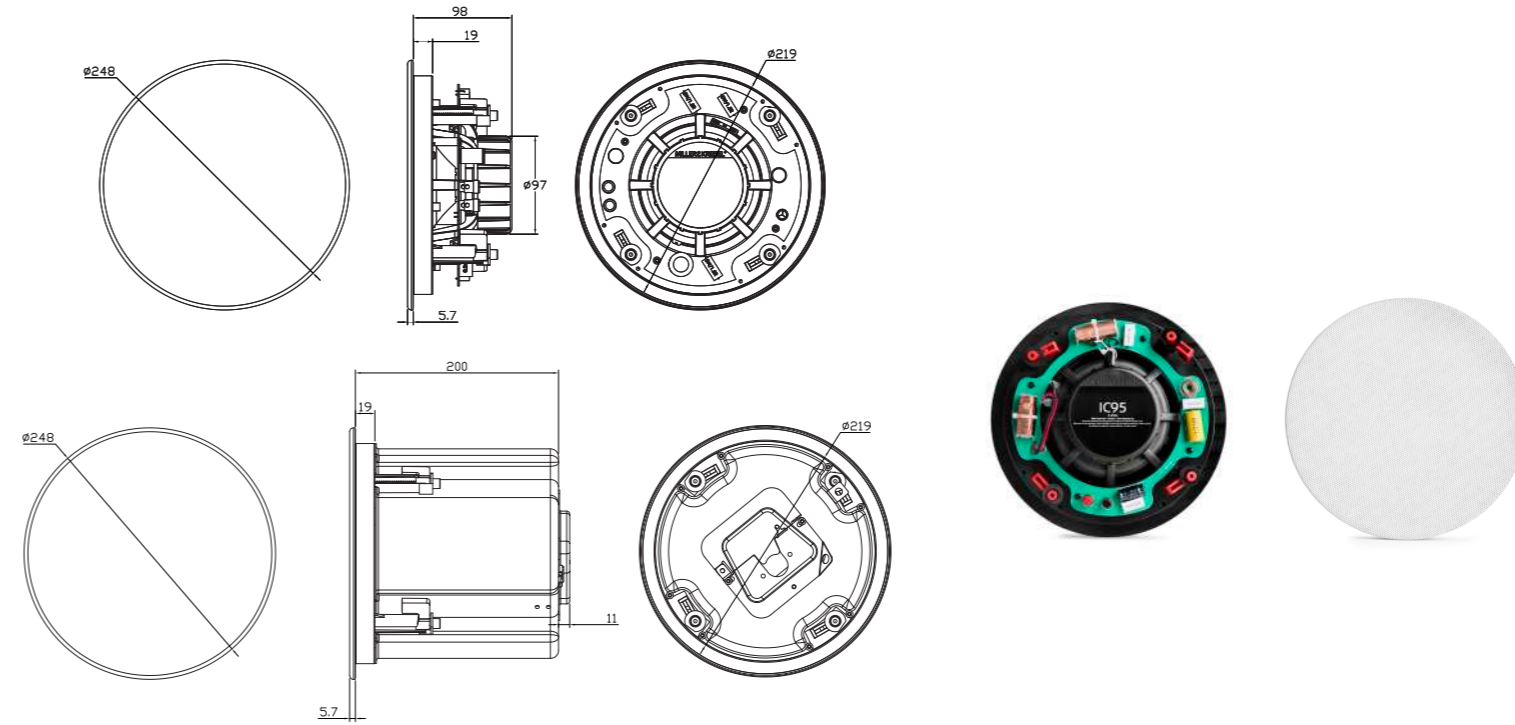

IM  
S  
E  
R  
I  
E  
S





## IW28S In-Wall Subwoofer

Decades of M&K Sound's experience and insight have been applied to the design of the truly invisible IW28S subwoofer. Its high performance 8-inch woofers were originally developed for the Miller & Kreisel V Series subwoofers (now replaced with the latest V+ Series). The IW28S subwoofers were ingeniously adapted to meet the extreme demands of shallow, flush-mount installations while delivering both the quantity and quality of deep bass that consumers and professionals have come to expect from Miller & Kreisel.

The specially tuned, ultra-fast and mass-loaded dual drivers employ aluminum shorting rings for minimal voice coil distortion at long excursion. Rigid paper pulp cones with high inner damping ensure stability at extreme output levels but with low resonance. A ultra-linear solid

ferrite magnet system provides effective dissipation of heat from the voice coil to prevent power compression from limiting the acoustic output of the system. The drivers are in full contact with the front baffle and the rear of the box for ideal mechanical stability to minimize driver resonances.



Impedance	4 Ohm
Bass Drivers	2 x 8" paper pulp
Frequency Response	28 Hz – 200 Hz, ± 3dB
Sensitivity (drive signal 100mVolt VA500 amp)	88 dB/1m
Grille Dimensions (HxW)	24.48 x 12.44", 622 x 312 mm
Baffle Dimensions (HxW)	24.25 x 12.04", 616 x 306 mm
Wall Cutout (HxW)	22.84 x 10.62", 580 x 270 mm
Mounting Depth	3.74", 95 mm
Weight	24.2 lbs / 11 kg
Grill Finish	White metal, paintable

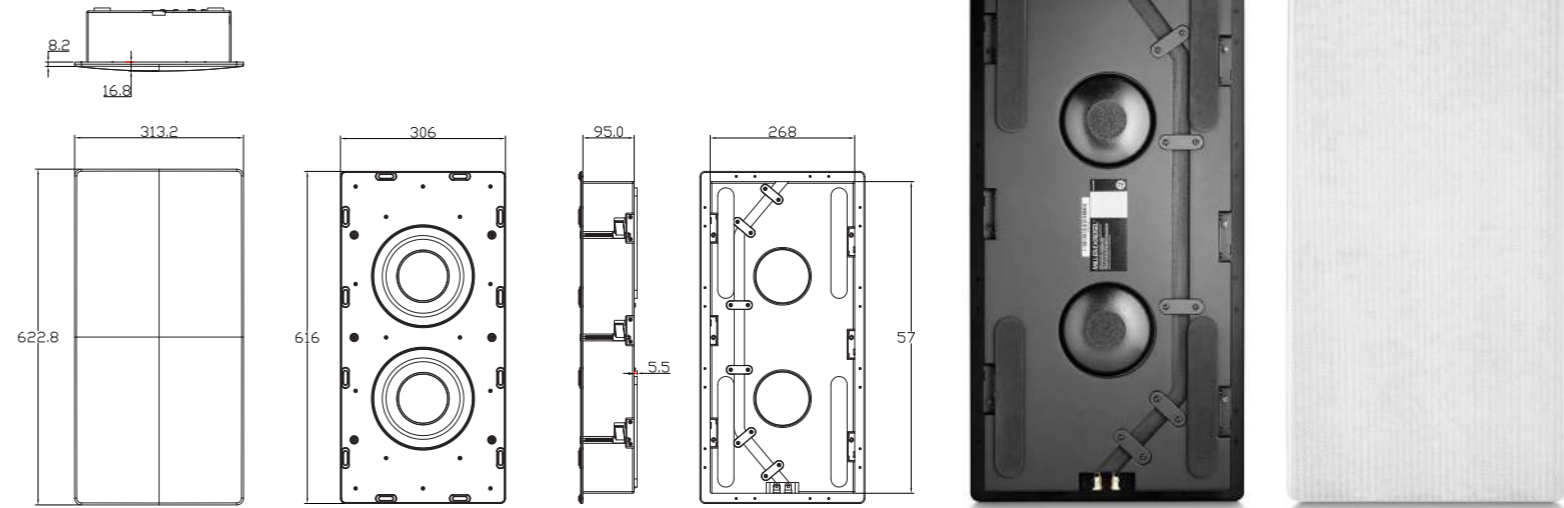

## VA500 Subwoofer Amplifier

The VA500 Subwoofer Amplifier uses a Class D-rated design with high efficiency, cool running and low standby voltage consumption. The product is a further development of the amps built into the popular M&K Sound V Series subwoofers. A Class D switch mode power module is designed with effective power reserves to deliver high amounts of clean power to M&K Sound's IW28S In-Wall Subwoofer. This enables an extraordinary, uncompromising handling of demanding deep bass transients. A precisely calibrated dynamic headroom control circuit constantly monitors the signal to prevent audible clipping, while maintaining the full dynamic range of modern digital audio formats.

Stereo inputs and line-level pass-through connections provide valuable flexibility for system building and future expansion. For perfect sonic integration with any satellite system, the VA500 incorporates an adjustable gain control including a fixed level position for reference setup, continuously variable phase (0-180 degrees), variable crossover frequency (60Hz - 200Hz) and three-position room adaptation. The VA500 is one standard rack unit high and is supplied with removable handles for mounting in a 19-inch pro rack and feet for standalone placement.

Continuous Output Power	.500W/4 Ohm, Class D
Peak Output Power	800W/4 Ohm
System Preamp	Analog
Line-Level Connections	Phono In, Phono Passthrough Out
Speaker Connections	5-way binding posts
Controls	Volume, Phase, Crossover
EQ Switch	3-Position Room Adaptation:

1. For one sub placed away from corners
2. For one sub placed near a corner
3. For one or two subs placed in corner(s)

Input Voltage	100-240 VAC (switchable), Auto On/Off
Dimensions (WxHxD)	16.88 x 1.74 x 8.81"
Dimensions (WxHxD) Rack size	429 x 44,4 x 224 mm
Dimensions (WxHxD) Rack size	19 x 1.74 x 8.81"
Dimensions (WxHxD) Rack size	483 x 44,4 x 224 mm
Weight	8.8 lbs / 4 kg

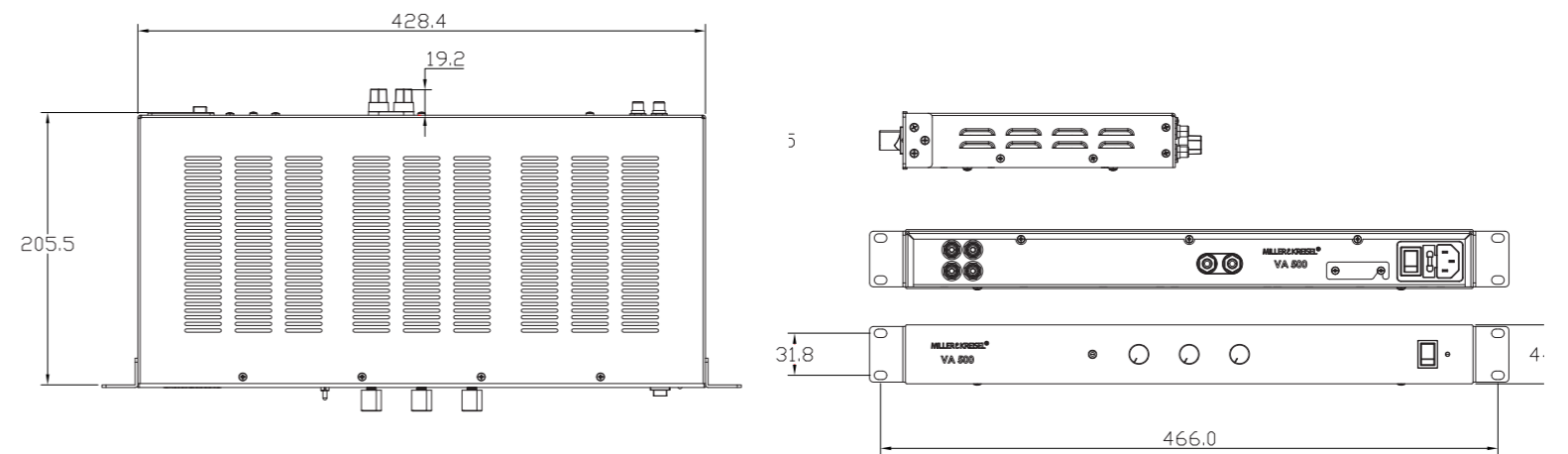

IW SERIES





## C15S Custom Install Subwoofer

Designed primarily for the custom installation market, the C15S builds on the technology of M&K Sound's X+ Series and V+ Series subwoofers. Output power is on a par with the dual 10-inch X+ 10 Subwoofer (without the advantages of the latter's push-pull configuration) in a single driver enclosure. The C15S is designed to enhance both large-room and bespoke installations. By using the specially tuned and matched

VA500 Blue Edition Subwoofer Amplifier (see below), the entire system has been custom designed from the ground up. This means the C15S can reproduce the deepest bass notes at levels loud enough to be both heard and viscerally felt.

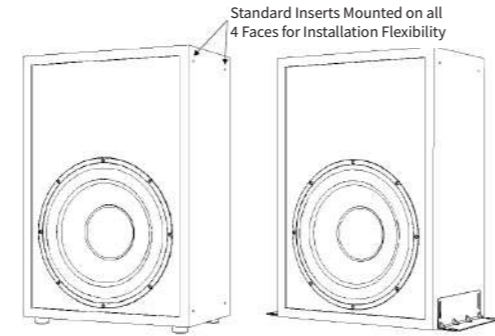
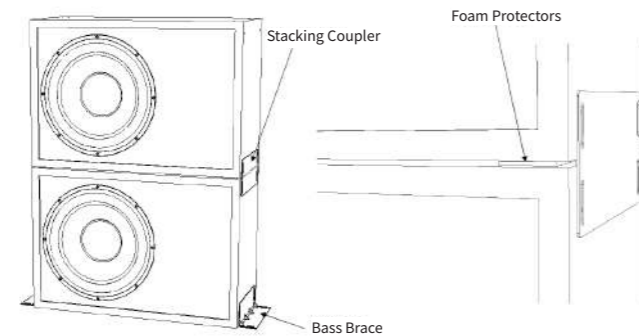

- Rubber Feet x 4**  
Vertical or Horizontal
- Bass Brace x 2**  
Vertical or Horizontal  
Tightens Bass  
Secures Subwoofer in Place
- Stacking Coupler x 2**  
Enables Subwoofer Stacking for Multi-Sub Installation
- Foam Protectors x 4**  
Used Between Subs for Stacking or Against Hard Surfaces to Protect and Absorb Vibration



## VA500 Blue Edition

The VA500 Blue Edition dedicated Class D amplifier comes packaged with the C15S Custom Install Subwoofer (see above). Its high efficiency characteristics, cool running and low standby voltage consumption represent enhancements of the amplifiers built into the popular M&K Sound V+ Series of subwoofers. The Class D switch mode power module is designed with reserves which can effortlessly deliver huge amounts of clean power to the C15S Custom Install Subwoofer. The resulting output of the VA500 Blue Edition is heard in its extraordinary and uncompromising handling of the power demanded of it.

## New Product

Impedance .....	4 Ohm
Bass Driver .....	15" Paper Pulp
Frequency Response .....	22-200Hz +/- 2dB
Sensitivity .....	90dB / 1m
Dimensions .....	725 x 498 x 298
Cabinet Solid .....	1" MDF w/Full Center
Finish .....	No-Nonsense Black Vinyl
Accessories .....	Mounting Brackets

Amplifier Power .....	500W RMS / 800W Peak
System Preamp .....	Analog
THD .....	<0.5% @ 500W
AC Power .....	100-240 VAC 50/60Hz
Inputs Line Level .....	RCA L/R
Outputs Line Level .....	RCA L/R
EQ Switch	1. Center of Wall 2. Near a Corner 3. Placed in a Corner 3-Position Room Adaptation

Controls .....	Volume, Phase, Crossover
Dimensions (WxHxD) .....	16.88 x 1.74 x 8.81"
Dimensions (WxHxD) .....	429 x 44,4 x 224 mm
Dimensions (WxHxD) Rack size .....	19 x 1.74 x 8.81"
Dimensions (WxHxD) Rack size .....	483 x 44,4 x 224 mm
Weight .....	8.8 lbs / 4 kg

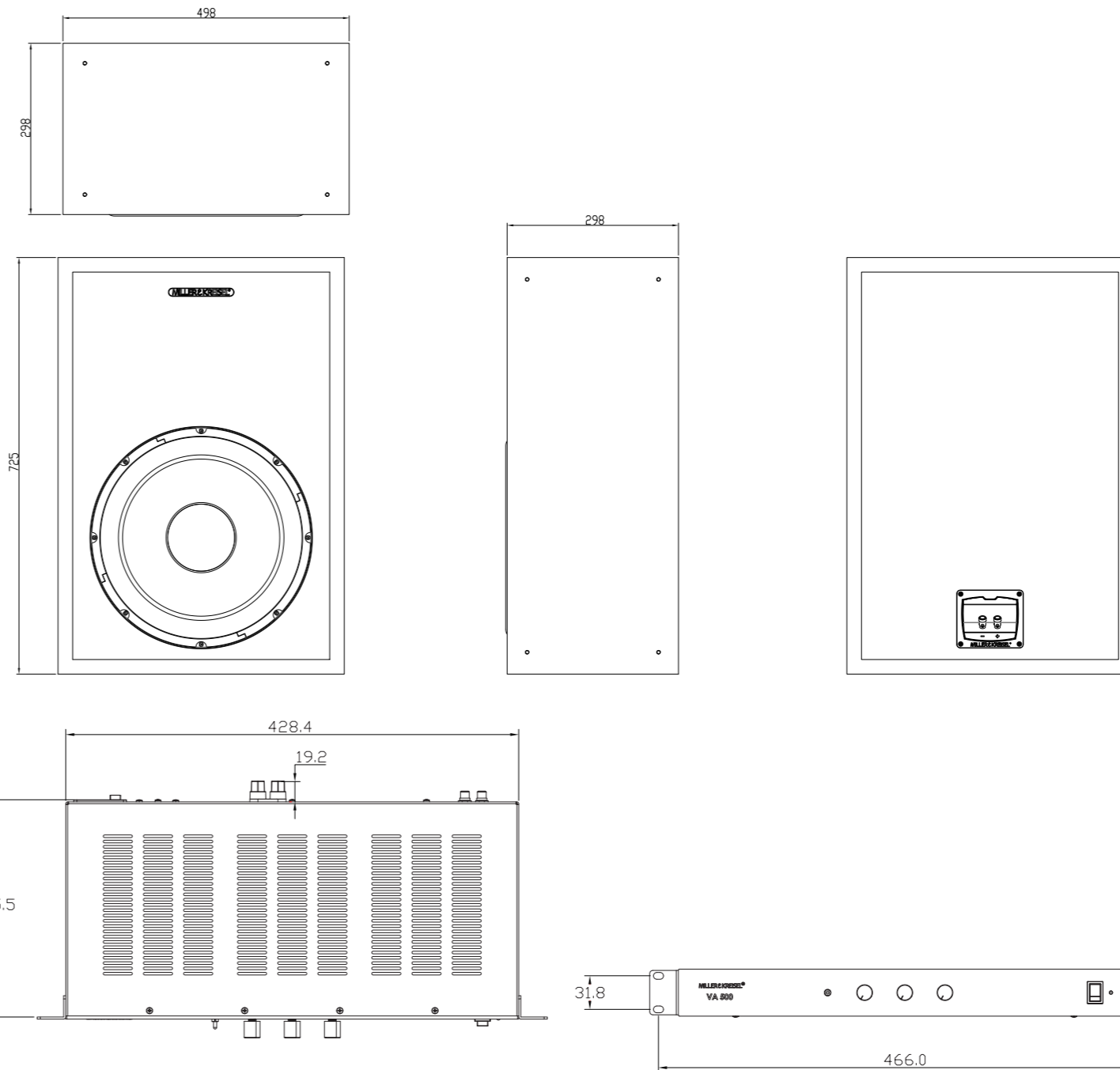





## S300 Speaker



One of M&K Sound's undisputed reference home entertainment speaker systems, the 300 Series of loudspeakers offers transparency and neutrality which surpasses those of far larger and more costly systems.

More compact than any speaker capable of rendering such clarity and pinpoint detail, the ultra-smooth S300 Speaker ensures unsurpassed, effortless realism in the largest home cinemas or listening rooms. While a dedicated left/right pair provides optimal imaging for two-channel sources, the use of an identical third speaker for center channel duties guarantees a seamless, consistent sound field in all dimensions. The S300 is the ultimate demonstration of M&K Sound's dedication to both innovation and quality.



Impedance: ..... 4 ohm  
 Recommended Amplifier Power: ..... 25-500W  
 Bass-Midrange: ..... 2 x 6.5" Glassfibre  
 High Frequency Drivers: ..... 3 x 1" Soft fabric dome  
 Frequency-response: ..... 60 Hz – 22KHz +/- 3dB  
 Sensitivity: ..... 93 dB, 2.83V1m  
 Dimensions HxWxD: ..... 15.5 x 13.4 x 13.0" / 395 x 340 x 330 mm  
 Weight: ..... 40.0 lbs / 18.2 kg  
 Finish: ..... Black satin

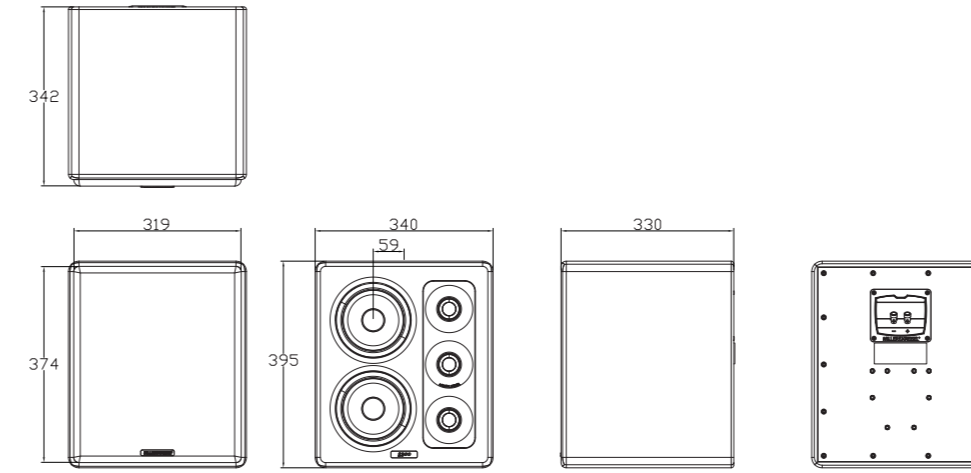

## S300T Tripole® Speaker



Miller & Kreisel invented the Tripole® configuration loudspeaker to do what no other conventional surround loudspeaker was able to. The installation of side and/or rear mounted S300Ts in home cinemas enhances the solidity and pinpoint placement of rear channel audio cues such as fly-overs, voices, effects or music, while also being able to recreate the realism of an ambient soundfield.

The S300T Tripole® with integral wall-mount bracket, employs the same front drivers and crossover technology as the S300 LCR loudspeaker, for a perfect acoustical and sonic timbral match. Independent, isolated chambers house two 4-inch drivers on each side for optimal surround coverage that rivals the huge array of sidewall speakers found in commercial movie theaters.



Impedance: ..... 4 ohm  
 Recommended Amplifier Power: ..... 25-400W  
 Bass-Midrange: ..... 1 x 6.5" Glassfibre  
 High Frequency Driver: ..... 1" Soft fabric dome  
 Side drivers: ..... 4 x 3.5" Glassfibre  
 Frequency-response: ..... 80 Hz – 22KHz +/- 3dB  
 Sensitivity: ..... 89 dB, 2.83V1m  
 Dimensions rear HxWxD: ..... 13.5 x 13.5 x 7" / 346 x 345 x 180mm  
 Dimensions front HxWxD: ..... 13.5 x 8.9 x 7" / 345 x 227 x 180mm  
 Weight: ..... 26.0 lbs / 12 kg  
 Finish: ..... Black satin / White satin

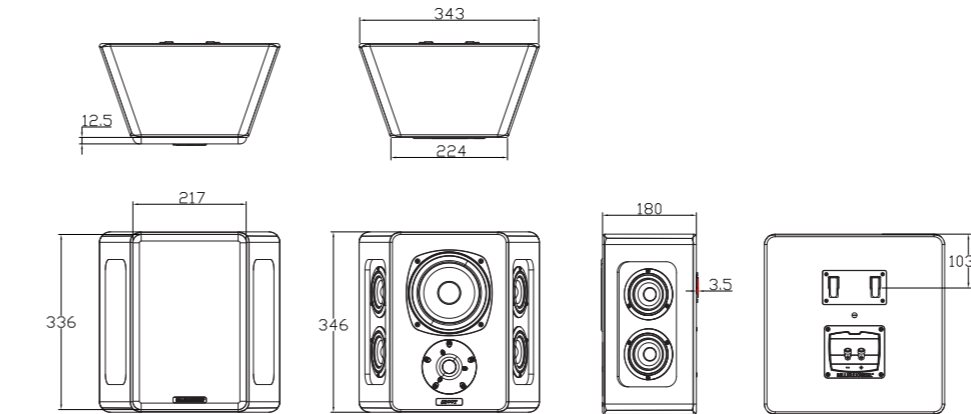

## MP300 On-Wall Speaker

Recognizing a growing demand for high level audio performance from an unobtrusive, décor-friendly enclosure, M&K Sound offers a shallower, wall-mounted version of the S300 Speaker.

By significantly reducing cabinet depth and revising overall dimensions, the MP300 on-wall Speaker becomes a discreet wall- or ceiling-based monitor which retains all the audio qualities of its S300 sibling. By optimizing the crossover circuitry and capitalizing on the acoustical benefits of wall mounting, the MP300 earns its place as a rightful member of the S300 family. The MP300 Speaker's modest dimensions and extended placement options will appeal to the style-conscious music or movie lover.



Impedance: ..... 4 ohm  
 Recommended Amplifier Power: ..... 25-500W  
 Bass-Midrange: ..... 2 x 6.5" Glassfibre  
 High Frequency Drivers: ..... 3 x 1" Soft fabric dome  
 Frequency-response: ..... 80 Hz – 22KHz +/- 3dB  
 Sensitivity: ..... 92 dB, 2.83V1m  
 Dimensions top HxWxD: ..... 15.5 x 13.4 x 6.3" / 394 x 339 x 177 mm  
 Dimensions bottom HxWxD: ..... 15.5 x 13.4 x 5.6" / 394 x 339 x 142 mm  
 Baffle Angel: ..... 5°  
 Weight: ..... 26.0 lbs / 12 kg  
 Finish: ..... Black satin / White satin

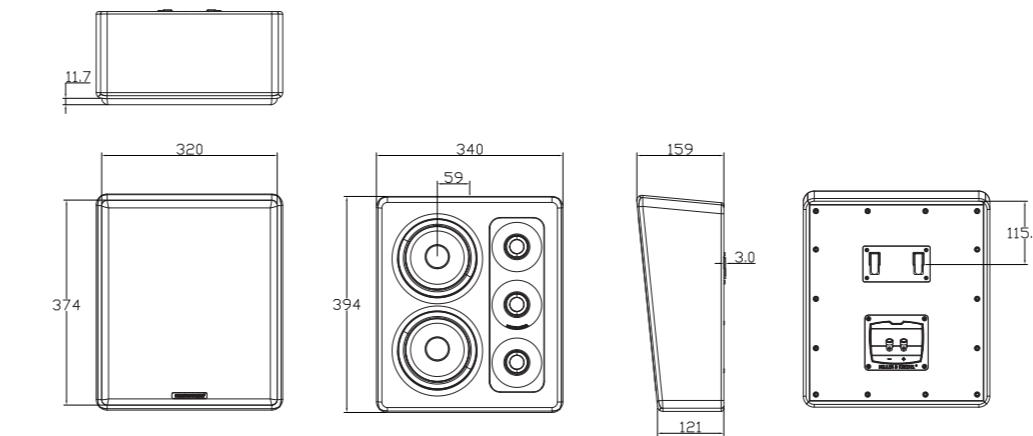

# 300 SERIES



“

**I've never heard a sub/sat system  
anywhere near this price point as tight and  
expressive and as tonally and harmonically  
complex as the M&K”**

*Neil Gader  
The Absolute Sound, 2022*





## S150 Speaker **Acoustic Upgrade**

The legendary M&K Sound S150 Speaker's performance is the culmination of more than 50 years of research, design and acoustic innovation. The resulting front soundstage loudspeaker has been embraced by hundreds of audio professionals as their reference studio monitor.

The S150 has also become an indispensable loudspeaker for the most discerning home audiophiles and cineastes. What this updated version of the legendary studio monitor does is convey exactly what is there in the recorded source, no more and no less. Essentially, the S150 does pretty much nothing, except open up a wide, clean and clear window on every aspect of recorded sound. Allow yourself to shift your personal focus between specific details, instruments or voices, while never losing sight of the totality of the overall musical or filmic experience. The S150 carries the coveted THX Certified Ultra 2 badge for the ultimate home cinema experience.



Impedance: ..... 4 ohms  
 Recommended Amplifier Power: ..... 25-500W  
 Bass-Midrange: ..... 2 x 5,25" Fiberglass  
 High Frequency Array: ..... 3 x 1.1" Soft Fabric Dome  
 Frequency-response: ..... 75 Hz – 20KHz +/- 3dB  
 Sensitivity: ..... 92 dB, 2.83V1m  
 HxWxD: ..... 31,8 x 26,6 x 30,8 cm / 12,5 x 10,4 x 12,2"  
 Weight ..... 11.5 kg / 25.4 lbs  
 Finish: ..... Black Satin / White Satin

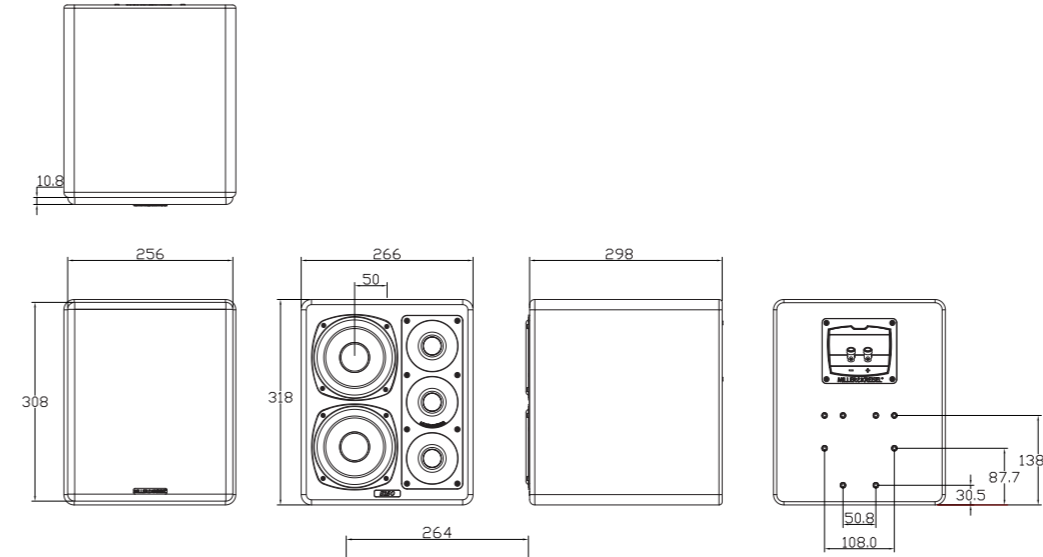

## S150T Tripole® Speaker **Acoustic Upgrade**

Side- or rear-mounted speakers in a multi-channel audio system pose a radically different set of performance challenges when compared to two speakers set up in a conventional stereo system. Surround speakers are typically positioned much closer to the listener but deliver sound to the audience's ears from multiple directions in a room. The proprietary Miller & Kreisel Tripole® configuration - essentially two speakers mounted in a single cabinet - is the first and only technology to deliver both sound effects placement accuracy and an enveloping surround field simultaneously.



The Miller & Kreisel S150T Tripole®, which brandishes THX Certified Ultra 2 status, combines front- and side-mounted drivers to channel a surround image both directly and indirectly into the listening area, much like the action of the sidewall loudspeakers in a commercial cinema.



Impedance: ..... 4 ohms  
 Recommended Amplifier Power: ..... 5-200W  
 Bass-Midrange: ..... 1 x 5,25" Fiberglass  
 High Frequency Driver: ..... 1.1" Soft Fabric Dome  
 Side drivers: ..... 2 x 3.5" Paper Pulp  
 Frequency-response: ..... 80 Hz – 20KHz +/- 3dB  
 Sensitivity: ..... 86 dB, 2.83V1m  
 Back HxWxD: ..... 27 x 26.5 x 15 cm / 10.6 x 10.4 x 5.9"  
 Front HxWxD: ..... 27 x 16.5 x 15 cm / 10.6 x 6.4 x 5.9"  
 Weight ..... 4.8 kg / 10.6 lbs  
 Finish: ..... Black Satin / White Satin

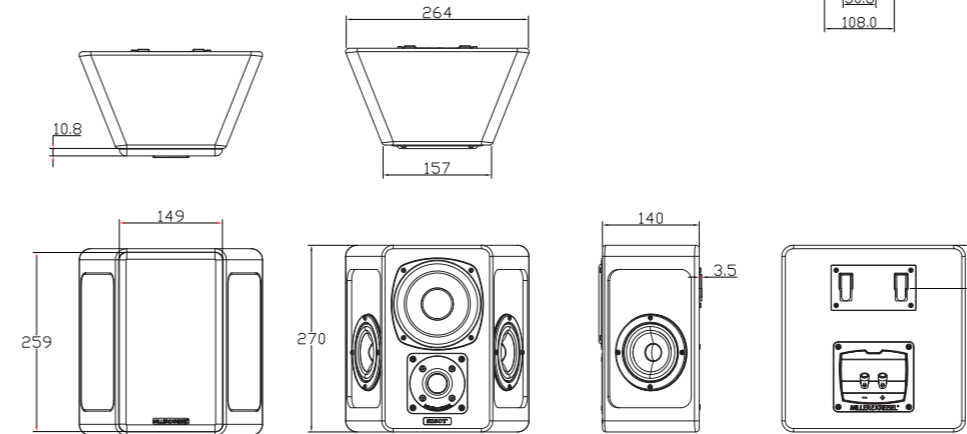

## MP150 On-Wall Speaker **Acoustic Upgrade**

For environments where stand mounting or desktop placement is not an option, M&K Sound offers the MP150, an on-wall configuration of the state-of-the-art S150 loudspeaker. The MP150 features the same mechanical and aesthetic architecture as M&K Sound's MPS2520P professional monitor and the legendary S150.

The MP150 uses identical 'professional-grade' 1.1-inch soft fabric dome tweeters and two 5.25-inch glass fiber mid-range drivers, as found in the 150 Series family of products at large. This commonality of components, drivers and technologies across the range means the MP150 can deliver that same uncompromising sound quality heard in recording studios and post-production facilities worldwide.



Impedance: ..... 4 ohms  
 Recommended Amplifier Power: ..... 25-400W  
 Bass-Midrange: ..... 2 x 5.25" Fiberglass  
 High Frequency Array: ..... 3 x 1" Soft Fabric Dome  
 Frequency-response: ..... 75 Hz-20KHz +/- 3dB  
 Sensitivity: ..... 92 dB, 2.83V1m  
 Back HxWxD: ..... 30 x 26.6 x 14.1 cm / 11.8 x 10.4 x 5.5"  
 Front HxWxD: ..... 31.7 x 26.6 x 10.8 cm / 12.4 x 10.4 x 4,2"  
 Weight ..... 8.3 Kg / 18.3 lbs  
 Finish: ..... Black Satin / White Satin

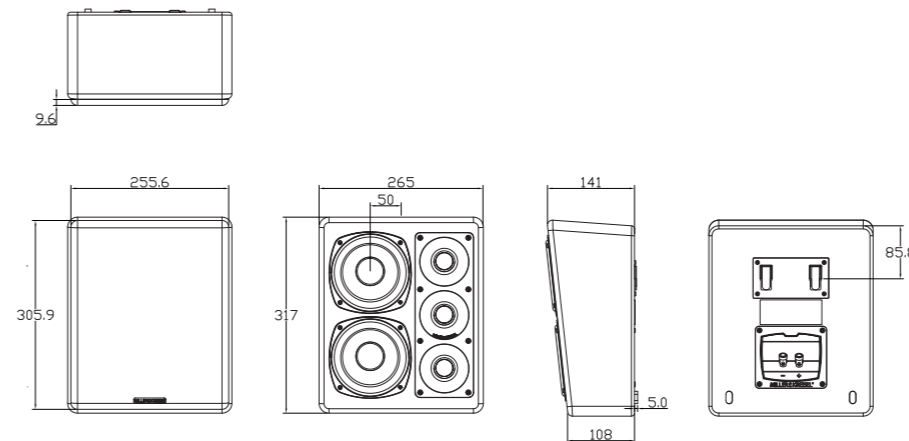

# 150 SERIES





## LCR950 Speaker **Acoustic Upgrade**

The LCR950 carries a THX Certified Select 2 badge and takes full advantage of M&K Sound's legacy. The compact front left/center/right (LCR) speaker is perfect for small-to-midsize home cinemas.

The LCR950 is replete with the identical drivers and crossover components as M&K's active professional studio monitors and 150 Series. The dual bass-midrange drivers were specially designed for extended dynamic range performance and low compression properties at moderate-to-high listening levels. With the LCR950's highly articulate 1-inch soft fabric dome tweeter, this handsome loudspeaker is capable of offering the superior performance for which M&K Sound is renowned. Excellent on- and off-axis response enables endless placement flexibility and perfect imaging at all listening positions.



Impedance.....	4 ohms
Recommended Amplifier Power.....	25-400 watt
Bass-Midrange.....	2 x 5.25" Polypropylene
High Frequency driver.....	1" Soft fabric dome
Frequency response.....	80-20Khz +/-3dB
Sensitivity.....	90 dB, 2,83V1m
Dimensions HxWxD.....	15.9 x 6.8 x 7.4" / 406 x 175 x 188 mm
Weight.....	15,2lbs / 6,9 kg
Finish.....	Black satin

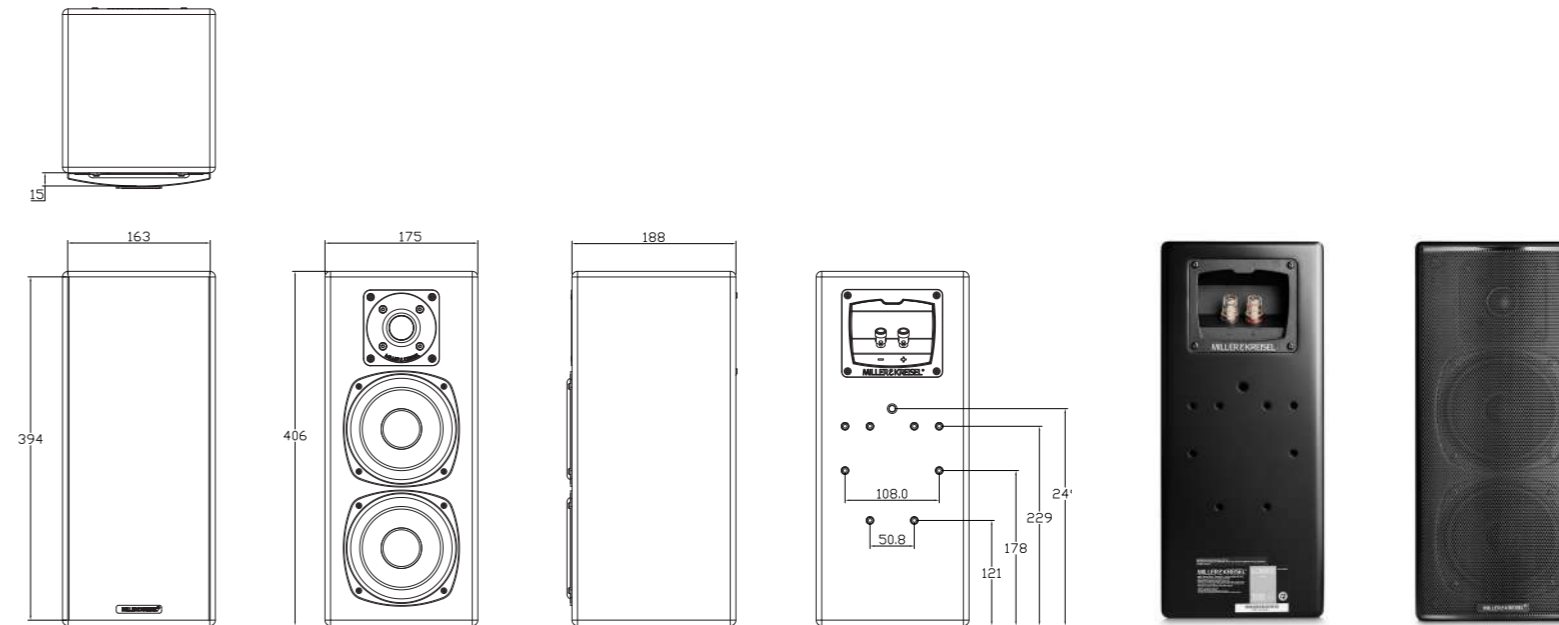

## MP950 On-Wall Speaker **Acoustic Upgrade**

The MP950 On-Wall Speaker is fully timbre-matched to the LCR950 but offers a shallow-depth profile for more design conscious environments.

The elegant MP950, with its choice of stylish White or Black Satin finishes, features identical drivers to the LCR950 loudspeaker. Designed specifically for on-wall applications, the MP950 houses a customized crossover network to compensate for boundary wall effects.

The MP950 is ideal for discreet placement around a flat panel display or as a low-profile surround speaker. A heavy-duty mounting bracket is included for anchoring the speaker vertically to a wall.

Impedance.....	4 ohms
Recommended Amplifier Power.....	25-200 watt
Bass-Midrange.....	2 x 5.25" Polypropylene
High Frequency driver.....	1" Soft fabric dome
Frequency response.....	80-20Khz +/- 3dB
Sensitivity.....	90 dB, 2,83V1m
Dimensions HxWxD.....	19.6 x 6.8 x 3.9" / 500 x 175 x 100 mm
Weight.....	14 lbs / 6,6 kg
Finish.....	Black satin / White satin

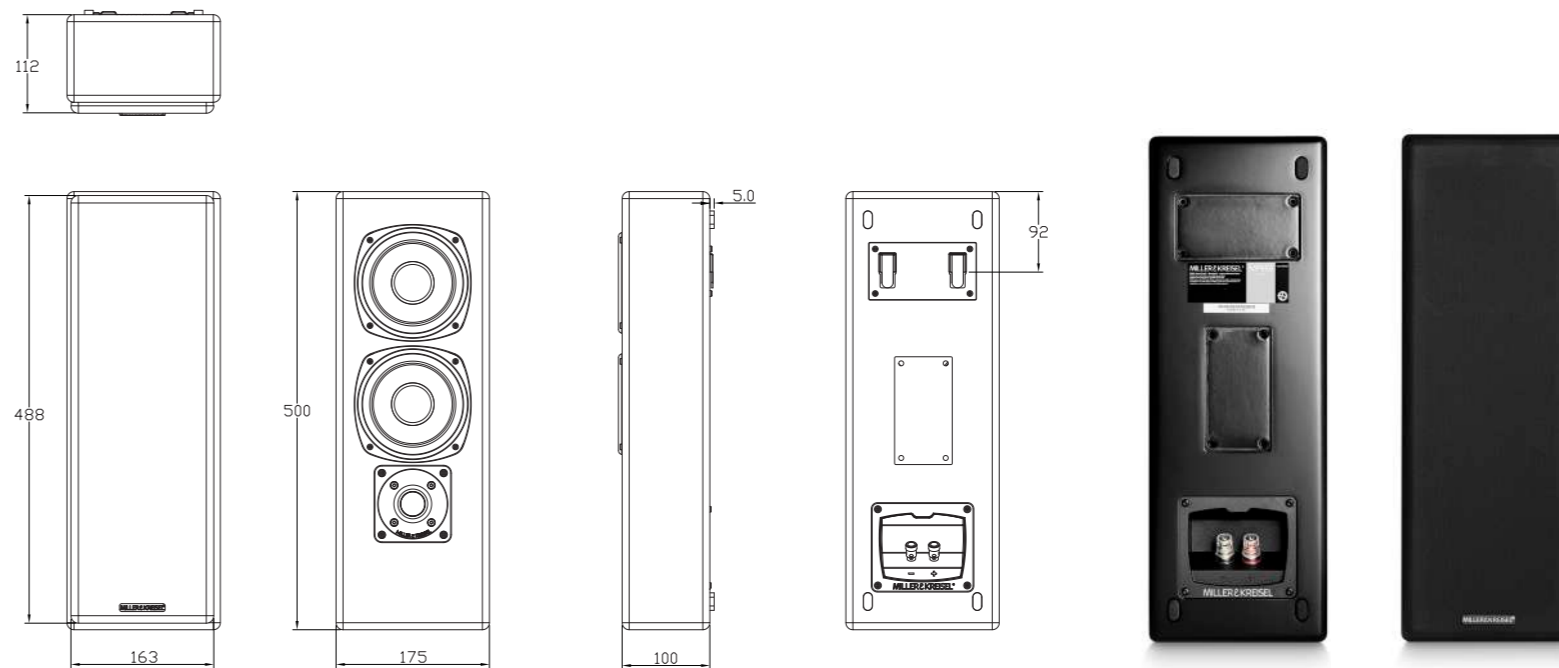



## LCR750 Speaker **Acoustic Upgrade**

The latest version of the Miller & Kreisel 750 Series of speakers takes the THX Certified Select category to new levels, and the entire line recently underwent a set of radical performance and acoustical upgrades.

Innovative and high-performance technologies from the reference S150 Series have now been integrated into these convenient bookshelf-size speakers. Primed for small home cinemas and AV rooms, the LCR750 is a front soundstage loudspeaker capable of undeniable transparency and exceptional detail retrieval. Cohesive and smooth response combine with exemplary on- and off-axis response for perfect imaging at multiple listening positions.



Impedance.....	4 ohms
Recommended Amplifier Power.....	25-400 watt
Bass-Midrange.....	2 x 5.25" Polypropylene
High Frequency driver.....	1" Soft fabric dome
Frequency response.....	80-20Khz +/-3dB
Sensitivity.....	90 dB, 2,83V1m
Dimensions HxWxD.....	15.9 x 6.8 x 7.4" / 406 x 175 x 188 mm
Weight.....	15,2 lbs / 6,9 kg
Finish.....	Black Vinyl

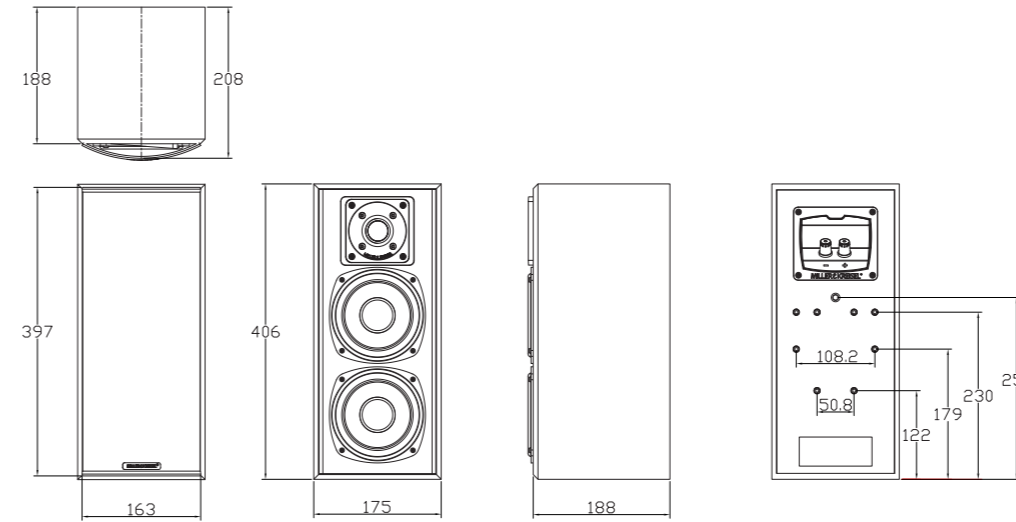

## LCR750C Speaker **Acoustic Upgrade**

The LCR750C is identical to the LCR750 but, due to its unique on-axis response characteristics, is designed to lie horizontally (either above or below a display) to maximize dialogue intelligibility and front sound stage effects placement in movie soundtracks.



Impedance.....	4 ohms
Recommended Amplifier Power.....	25-400 watt
Bass-Midrange.....	2 x 5.25" Polypropylene
High Frequency driver.....	1" Soft fabric dome
Frequency response.....	80-20Khz +/-3dB
Sensitivity.....	90 dB, 2,83V1m
Dimensions HxWxD.....	6.8 x 15.9 x 7.4" / 175 x 406 x 188 mm
Weight.....	15,2 lbs / 6,9 kg
Finish.....	Black Vinyl

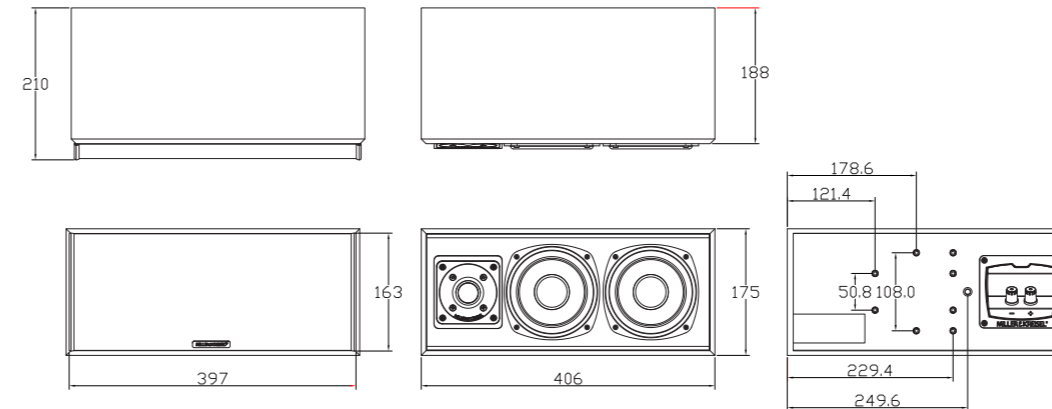

## SUR55T Tripole® Speaker **Acoustic Upgrade**

The SUR55T is M&K Sound's most compact Tripole® solution in the THX Certified Select class. The small speaker's rugged enclosure embodies operatic clarity and neutrality in performance and, while eschewing colouration or excessive warmth, quite simply reproduces surround sound as it is meant to be heard.

The SUR55T is timbre-matched to the 750 Series loudspeakers and uses the same integrated waveguide, aluminium rings, high-frequency prism system and convex metal front grille. Each speaker is designated as 'left' and 'right' for surround soundfield optimization and installation convenience. The SUR55T features two 3-inch mid-tweeters on each side of the speaker oriented in a dipole configuration, combined with a front-mounted 1-inch soft-dome tweeter and 5.25-inch direct-radiating mid-woofer. This driver arrangement ensures that the SUR55T can provide even sound distribution throughout the listening area with pinpoint accuracy and a truly enveloping soundfield.



Impedance.....	4 ohms
Recommended Amplifier Power.....	25-200 watt
Bass-Midrange.....	5.25" Polypropylene
High Frequency driver.....	1" Soft fabric dome
Side driver.....	2 x 3,5" Coated texture taper
Frequency response.....	80-20Khz
Sensitivity.....	85 dB, 2,83V1m
Dimensions HxWxD.....	10.1 x 6.8 x 7.4" / 257 x 175 x 188 mm
Weight.....	10,25 lbs / 4,7 kg
Finish.....	Black Vinyl

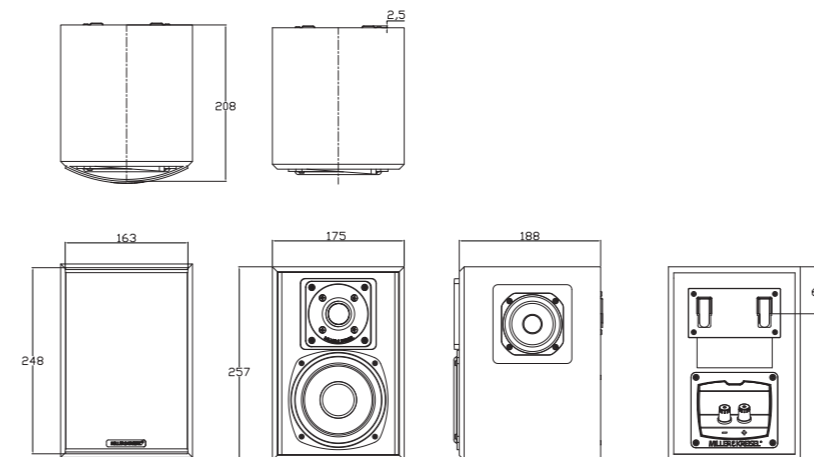

# 750 SERIES



“

## D Series

**Elegant performance loudspeaker  
designed for today's living spaces  
becomes 'a part of your surroundings'**

*M&K Sound, Nov 2022*





## D85 Speaker New Product

The low-profile and design-conscious D85 is a truly home-friendly music or TV loudspeaker. Its incredible loudness capability, yet accurate music and film sound reproduction, defy its small dimensions. Without requiring unsightly or costly burrowing into walls, the discreet D85 is innately suited to being mounted on a wall, or sitting on a bookshelf or speaker stand around the home.

The D85 uses the same tweeter found in the iconic 150 Series loudspeakers and boasts an incredible 89 dB of sensitivity, producing incredible dynamics from a tiny enclosure. Available in Satin White or Silver Grey, the 3.74-inch-deep D Series speaker doubles as both a work of art and a conveyor of your favourite playlists around the home.

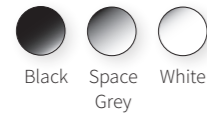

Black Space White  
Grey

Nominal System Impedance	.....	4 ohm (Z-min 3.4 ohm)
Frequency Response	.....	95-20K Hz (average response in room +/- 3 dB)
Frequency Roll Off	.....	70 Hz (-9 dB 80 Hz near field)
Crossover Frequency	.....	1.6K Hz "Phase focused" (2nd order)
Tweeter	.....	1 x 1,1" Dome, Coated silk dome / Low compression
Woofer	.....	1 x 5.25" Polypropylene Cone, Inverted Dust cap
Power Handling	.....	110 watt Long term IEC-268-5 (cycled input 77-20K Hz)
Power Handling	.....	60 watt Rated IEC-268-5 (constant input 77-20K Hz)
Recommended Amp Power	.....	25-200 watt Recommended Amp Power Min / Max
Sensitivity	.....	89 dB Average SPL 2.83 volt / 1mtr (on axis 200-10K Hz)
Max SPL Continued	.....	106 dB, Sinewave 100-8000 Hz THD<10%
Max SPL Peak	.....	112 dB Sinewave 100-8000 Hz / THD < 10%
System Principle	.....	Sealed enclosure
Connection	.....	Terminal Gold plating. Push terminal 4mm Cable
Finish	.....	Paint. Matte White, Black or Grey
Cabinet dimensions	.....	H x W 9.65 x 7.68 inch / 245 x 195 mm
Placement Options	.....	Keyhole mounting, prepared for alternative brackets
Cabinet depth	.....	D 3.74 inch / 95 mm
Dimensions Grille	.....	H x W 9.41 x 7.44 inch / 239 x 189 mm
Weight	.....	Nett 07.7 lbs / 3.5 kg

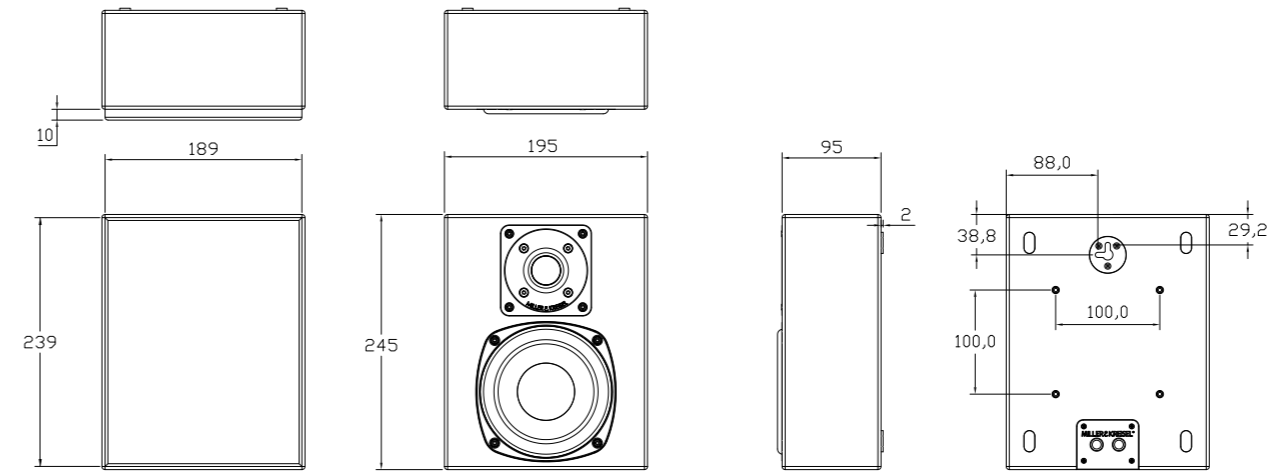

## D95 Speaker New Product

The D95 retains the identical slim depth profile as the D85 at 3.74 inches. Even compensating for a larger 6.5-inch woofer, the front fascia still only measures a compact 11.81 x 9.45 inches. The more substantial housing means that sensitivity hikes up to 91 dB for even more of the dynamics and resolution that users have come to expect from M&K Sound.

In addition to the Satin White and Silver Grey colour choices of the D85, the D95 can also be ordered in a sophisticated High Gloss Black finish. The three colour options mean that the D Series loudspeakers can seamlessly blend with any home décor palette. The D95 is an ornate and lifestyle-friendly loudspeaker designed to punch well above its weight.

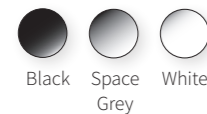

Black Space White  
Grey

Nominal System Impedance	.....	4 ohm (Z-min 3.4 ohm)
Frequency Response	.....	90-20K Hz (average response in room +/- 3 dB)
Frequency Roll Off	.....	70 Hz (-9 dB 80 Hz near field)
Crossover Frequency	.....	1.6K Hz "Phase focused" (2nd order)
Tweeter	.....	1 x 1,1" Dome Coated silk dome / Low compression
Woofer	.....	1 x 6.5" Polypropylene Cone, Inverted Dust cap
Power Handling	.....	140 watt, Long term IEC-268-5 (cycled input 77-20K Hz)
Power Handling	.....	75 watt, Rated IEC-268-5 (constant input 77-20K Hz)
Recommended Amp Power	.....	25-300 watt, Recommended Amp Power Min / Max
Sensitivity	.....	91 dB, Average SPL 2.83 volt / 1mtr (on axis 200-10K Hz)
Max SPL Continued	.....	109 dB, Sinewave 100-8000 Hz / THD < 10%
Max SPL Peak	.....	115 dB, Sinewave 100-8000 Hz / THD < 10%
System Principle	.....	Sealed enclosure
Connection	.....	Terminal Gold plating Push terminal 4mm Cable
Finish	.....	Paint. Matte White, Black or Grey
Cabinet dimensions	.....	H x W 11.81 x 9.45 inch / 300 x 240 mm
Placement Options	.....	Keyhole mounting, prepared for alternative brackets
Cabinet depth	.....	D 3.74 inch / 95 mm
Dimensions Grille	.....	H x W x D 11.57 x 9.21 inch / 294 x 234 mm
Weight	.....	Netto 10.8 lbs / 4.9 kg

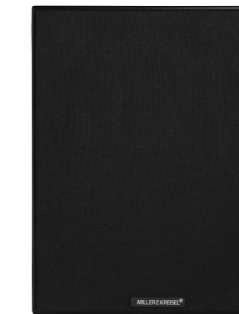
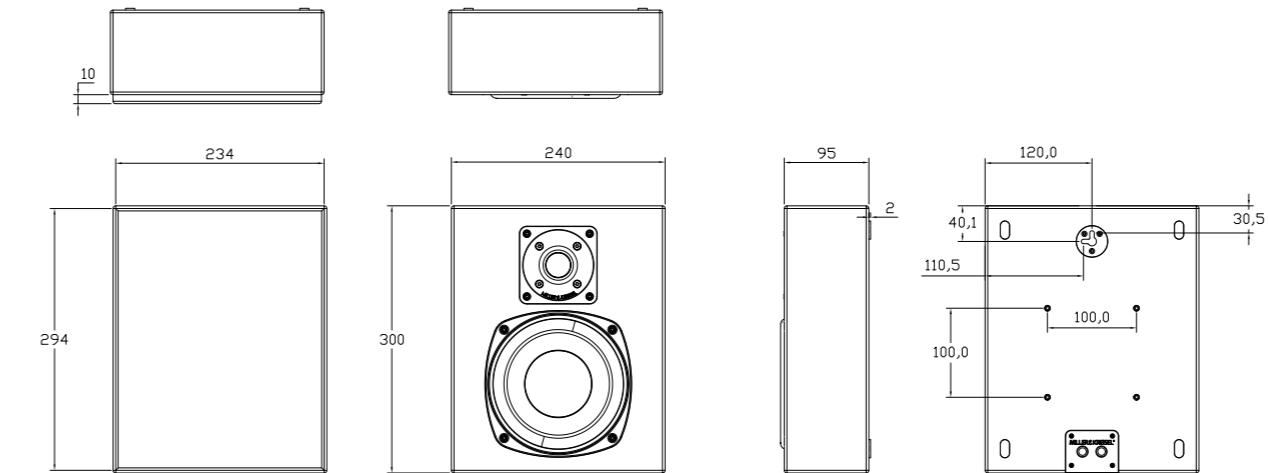

# D SERIES





## M70 Speaker

Both form and function are optimized for today's listening and viewing experience with M&K Sound's latest version of the M70 Speaker. This décor-friendly on-wall design loudspeaker enables customers to perform a simple installation at home. While embodying performance and aesthetics as its core elements, the M70's ultra-slim, low-profile enclosure is the benchmark of the M Series.

All models in the range are designed specifically for direct on-wall mounting, and are fitted with integrated rear panel brackets and specially designed damping pads to ensure a vibration-free installation. Mounting accessories are included for an easy and hassle-free deployment. The entire M Series features new and improved components and crossover circuits, making each model truly voice-matched to its siblings.

Impedance: ..... 4 ohm  
 Frequency Response: ..... 80 – 20Khz (+/- 2dB)  
 Frequency Roll Off: ..... 80Hz (-10dB 80 Hz near field wall mounted)  
 Crossover Frequency: ..... 1.8 KHz  
 Tweeter (shielded): ..... 1" Dome – Coated silk dome / Neodymium magnet  
 Woofer (shielded): ..... 2 x 4" Coated glass fibre  
 Power Handling: ..... 125 watt (Long term IEC-268-5)  
 Power Handling: ..... 70 watt (Rated IEC-268-5)  
 Recommended Amplifier Power: ..... 25-200W  
 Sensitivity: ..... 89 dB  
 System Princip: ..... Sealed enclosure  
 Wall Connection: ..... Terminal gold plating (Screw for 5 mm cable / Banana)  
 Dimensions HxWxD: ..... 18.1 x 5.1 x 3.3" / 46 x 13 x 8,8 cm  
 Weight: ..... 8.4 lb / 3,8 kg  
 Finish: ..... Black / White satin

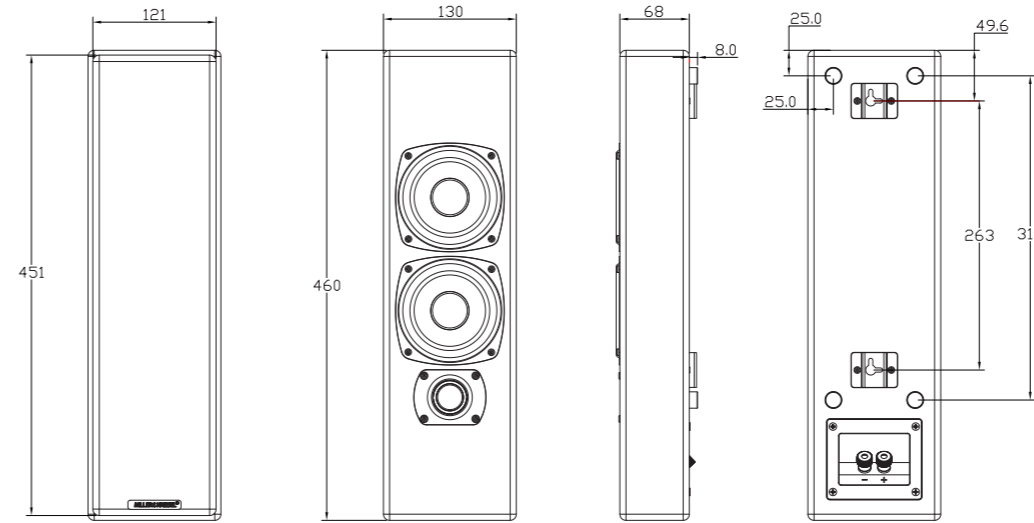

## M50 Speaker

The redesigned M50 offers a more compact solution than the larger M70 for customers who require a more discreet on-wall home cinema or music system.

The M50 employs identical drivers to the M70 and M40T models, and is available in stylish Black Satin and White Satin color options. Voice-matched to the rest of the M Series, the M50 can be an ideal solution for building out a bijou home cinema or multi-room music system on a budget.

Nominal system impedance: ..... 4 ohm (Z-min 4.9 ohm)  
 Frequency Response: ..... 100-20Khz (average response in room +/- 2dB)  
 Frequency Roll Off: ..... 100Hz (-6dB 100 Hz near field wall mounted)  
 Crossover Frequency: ..... 1.8 KHz "Phase focused" (4th&2nd order)  
 Tweeter (shielded): ..... 1" Dome – Coated silk dome / Neodymium magnet  
 Woofer (shielded): ..... 4" Coated glass fibre  
 Power Handling: ..... 80 watt Long term IEC-268-5 (cycled input 100-20Khz)  
 Power Handling: ..... 50 watt (Rated IEC-268-5 (constant input 100-20Khz)  
 Recommended Amplifier Power: ..... 25-125 watt  
 Sensitivity: ..... 85 dB (Average SPL 2.83 Volt / 1mtr (on axis 200-10KHz)  
 System Princip: ..... Sealed enclosure  
 Wall Connection: ..... Terminal gold plating (Screw for 5 mm cable / Banana)  
 Dimensions HxWxD: ..... 9.8 x 5.1 x 3.3" – 25 x 13 x 8,5cm (incl grill)  
 Weight: ..... 4.4 lb / 2.0 kg  
 Finish: ..... Black / White satin

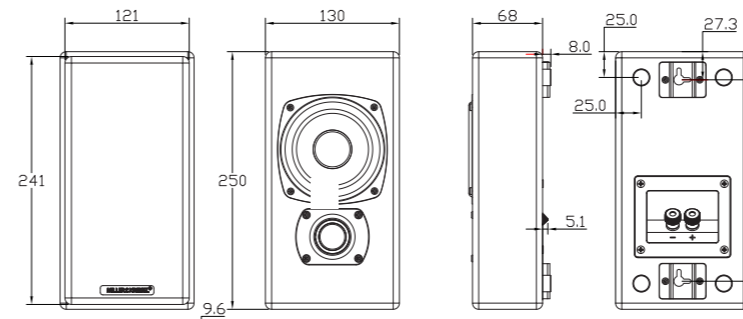

## M40T Tripole® Speaker

The M40T Tripole® is a multi-polar side- and rear-channel speaker, and forms part of the compact M Series family. This nifty surround loudspeaker designed for small home cinemas offers the benefits of M&K Sound's exclusive Tripole® technology in a remarkably compact and affordable package.

The M40T combines direct radiating front mounted drivers with dipolar side-mounted drivers in the same cabinet. When this unique driver arrangement is blended with M&K Sound's proprietary Phase Focused Crossover, the M40T Tripole® provides extraordinarily even dispersion of sound across a broad listening area with superior imaging and sonic quality.

Nominal system impedance: ..... 4 ohm (Z-min 4.6 ohm)  
 Frequency Response: ..... 100-20Khz (average response in room +/- 2dB)  
 Frequency Roll Off: ..... 100Hz (-6dB 100 Hz near field wall mounted)  
 Crossover Frequency: ..... 2.0 KHz "Phase focused" (4th&2nd order)  
 Tweeter (shielded): ..... 1" Dome – Coated silk dome / Neodymium magnet  
 Woofer (shielded): ..... 4" Coated glass fibre  
 Side drivers (shielded): ..... 2 X 3" (Polymer Coated Textured Paper)  
 Power Handling: ..... 80 watt Long term IEC-268-5 (cycled input 100-20Khz)  
 Power Handling: ..... 50 watt (Rated IEC-268-5 (constant input 100-20Khz)  
 Recommended Amplifier Power: ..... 25-125 watt  
 Sensitivity: ..... 85 dB (Average SPL 2.83 Volt / 1mtr (on axis 200-10KHz)  
 System Princip: ..... Sealed enclosure  
 Wall Connection: ..... Terminal gold plating (Screw for 5 mm cable / Banana)  
 Dimensions HxWxD: ..... 7.7 x 7.8 x 4.8" - 19.5 x 20 x 12,2 cm (incl grill)  
 Weight: ..... 6.5 lb / 2.9 kg  
 Finish: ..... Black / White satin

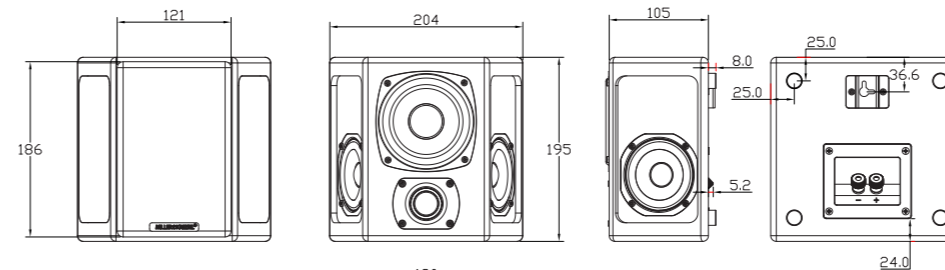

# M SERIES



## M90 Speaker New Product

M90 is a step-up to the M50 and M70 speakers. The décor-friendly On-Wall ultra slim and low enclosure design is the benchmark for all M Series.

In the NEW M90, we have added 2 additional bass drivers, it adds both sensitivity and bass response. Ideally suited for rooms where extra output is needed.

The M90 has each set of woofers in their own anti-resonant acoustic chamber, the center 2 working as a midrange, and the other 2 woofers covering bass frequencies. This is to ensure minimal distortion and cabinet resonances common with slim speakers.

The M90 is also phase aligned to operate as an ideal center channel speaker, with 100% symmetric coverage vertically and horizontally

In addition to the performance enhancements of the M90, it also sports a long profile, designed to match up to today's large format flat screen TV's for a more pleasing aspect ratio.

Nominal System Impedance	..... 4 ohm (Z-min 3.4 ohm)
Frequency Response	..... 70-20K Hz (average response in room +/- 2 dB)
Frequency Roll Off:	..... 70 Hz (-10 dB 80 Hz near field wall mounted)
Crossover Frequency:	..... 600 Hz / 2.0 KHz "Phased focused" (2nd order) Tapered
Tweeter (shielded):	..... 1" Dome Coated Silk dome / Neodymium magnet
Woofer	..... 4 x 4", Coated Glass Fiber
Power Handling:	..... 150 watt Long term IEC-268-5 (cycled input 80-20K Hz)
Power Handling:	..... 70 watt Rated IEC-268-5 (constant input 80-20K Hz)
Recommended Amplifier Power:	..... 25-200W (Recom. amp power to driver speaker)
Sensitivity:	..... 89 dB
System Princip:	..... Sealed enclosure
Connection: Terminal gold plating	..... Screw for 5mm Cable / Banana
Accessories	..... Yes. Wall mount Brackets/Screws/Gloves
Welcome card	..... Yes, "Included in packing"
Dimensions	..... HxWxD: 31.5 x 5.1 x 3.3" / 80 x 13 x 8.5 cm (incl grill)
Weight, Netto	..... 12.40 lbs / 5.62 kg
Finish:	..... Painted. Black / White Satin

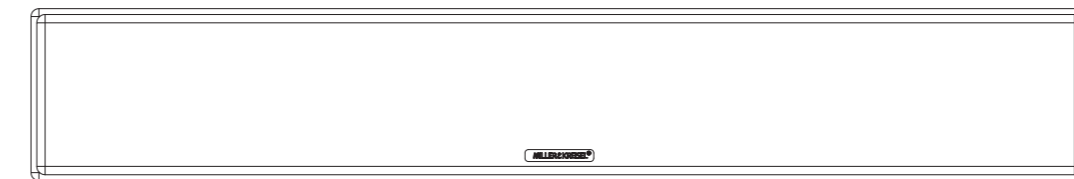
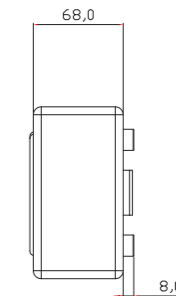
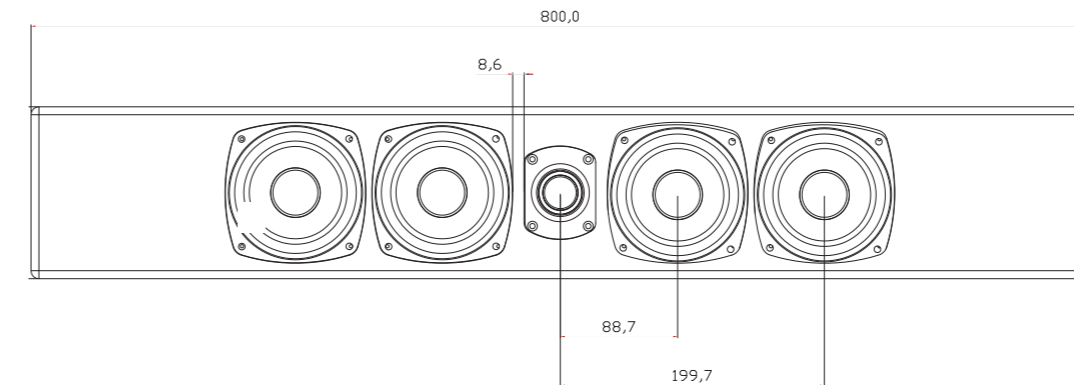

# M SERIES



“

FIDELITY 

**Big things sometimes come in  
small packages or perhaps it's just  
that real pros know exactly how  
to push the boundaries”**

*Stefan Gawlick, Fidelity  
Recording and Mastering Engineer*





## MPS2520P Studio Monitor

The MPS2520P Studio Monitor is endowed with a total of five driver units providing impressive and reference-grade audio from an ultra-compact footprint. Internal dual-channel power amplifiers drive the bass-midrange and high frequency sections with total precision and full control of signal dynamics. The two 5.25-inch bass-midrange drivers are fine-tuned and optimized for the unique sealed box enclosure. Combined with triple-stacked tweeters operating down to 1.2 kHz, the MPS2520P's sound is fast, responsive and highly detailed.

The active loudspeaker's superior qualities have been honed and perfected to facilitate the editing, mastering and mixing of music and movie reference recordings. M&K Sound's MPS2520Ps are designed for easy system setup using the built-in high-pass filter and therefore smooth integration with M&K's subwoofers.

***The Choice of Professionals®***

Amplifier power bass-midrange: ..... 200watt RMS/400watt peak  
 Amplifier power high frequency: ..... 180watt RMS/360watt peak  
 Bass-midrange: ..... 2 x 5.25 Glassfibre  
 High frequency drivers: ..... 3 x 1,1" soft fabric dome  
 Frequency response: ..... 80-12KHz +/-1dB / 12-20KHz +/-2dB  
 Total Harmonic distortion: ..... <0.002% into 4 ohms LF Channel /  
 0.03% into 4 ohms HF channel

Signal to noise ratio: ..... 100dB  
 AC power consumption: ..... Standby/Average/Max 17W, 45W, 360W  
 AC line voltage: ..... 115VAC/60Hz 5A - 230VAC/60Hz 3.15A  
 Input impedance unbalanced ..... 11Kohm / balanced 22Kohm  
 Input sensitivity unbalanced 1 ..... 00mV 90dB 1m / balanced 200mV 90dB 1m  
 Max output level: ..... 110dB/100Hz  
 Max input: ..... 24dBu balanced  
 High pass filter: ..... Fixed 80 Hz (24dB)  
 Vertical directivity control: ..... Wide/Narrow - 50/30 Deg.  
 Dimensions HxWxD: ..... 12.8 x 10.6 x 15.8" / 327 x 270 x 401 mm  
 Weight: ..... 39.6 lbs / 18 kg  
 Finish: ..... Black satin

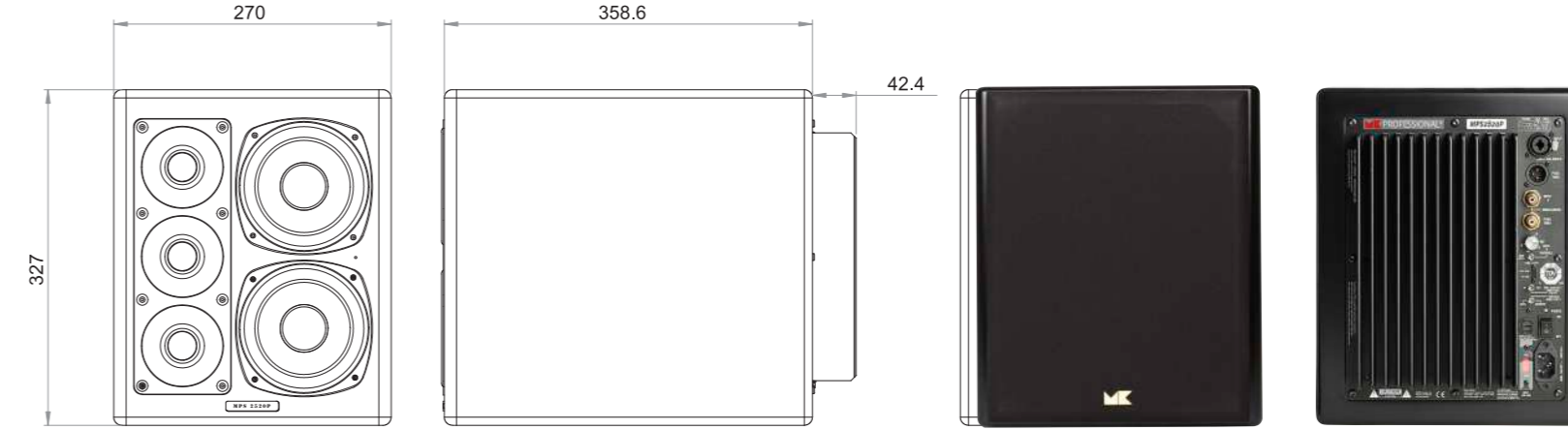

## MPS1620P Studio Monitor

The MPS1620P studio monitor features a long-stroke 6.5-inch driver and low-compression 1-inch dome tweeter designed to provide impressive and dynamic audio during the professional production of high-resolution recordings. The dual-channel power amplifiers drive both bass-midrange and high frequency sections independently, and with total precision and control.

The MPS1620P can operate either as a sealed or ported loudspeaker due its removeable 'port plug system' on the rear side of the unit. When operating the monitor with a subwoofer, the choice of a sealed box configuration with the filter set to 'normal' will provide the classic Miller & Kreisel sub/sat crossover configuration. When using the MPS1620P as a standalone monitor, the ported configuration with filter set to 'full range' will extend bass response and provide a more precise 'broadband' response for nearfield monitor applications. The MPS1620P is a flexible, high-precision studio monitor designed for use in the editing, mastering and mixing of professional music and movie audio recordings.

***The Choice of Professionals®***

Amplifier power bass-midrange: ..... 100watt RMS/200watt peak  
 Amplifier power high frequency: ..... 50watt RMS/100watt peak  
 Bass-midrange: ..... 1 x 6,5" polypropylene woofer  
 High frequency drivers: ..... 1 x 1" soft dome tweeter  
 Frequency response: ..... Sealed/normal setting 80-22KHz +/-2dB  
 Frequency response: ..... Sealed/full range setting/  
 (wall or console loaded) 45-22KHz +/-2dB

Frequency response: ..... Ported/normal setting 45-22KHz +/-2dB  
 Frequency response: ..... Ported/full range setting/  
 (wall or console loaded) 35-22KHz +/-2dB  
 Total Harmonic distortion: ..... < 0,025% into 8 ohms LF channel/  
 < 0.025% into 4 ohms HF channel

Signal to noise ratio: ..... 100 dB  
 AC power consumption: ..... Standby/Average/Max (15W, 30W, 240W)  
 AC line voltage: ..... 115VAC/60Hz 2A - 230VAC/50Hz 1A  
 Input impedance ..... unbalanced 11kohm / balanced 22Kohm  
 Input sensitivity unbalanced ..... 100mV 88dB 1m / balanced 200mV 88dB 1m  
 Max output level: ..... 106dB/100Hz  
 Max input: ..... 24dBu balanced  
 High pass filter: ..... Fixed 80 Hz (24dB)  
 Dimensions HxWxD: ..... 12.6 x 8.3 x 11.6" / 321 x 213 x 297 mm  
 Weight: ..... 20.3 lbs / 9,2 kg  
 Finish: ..... Black satin

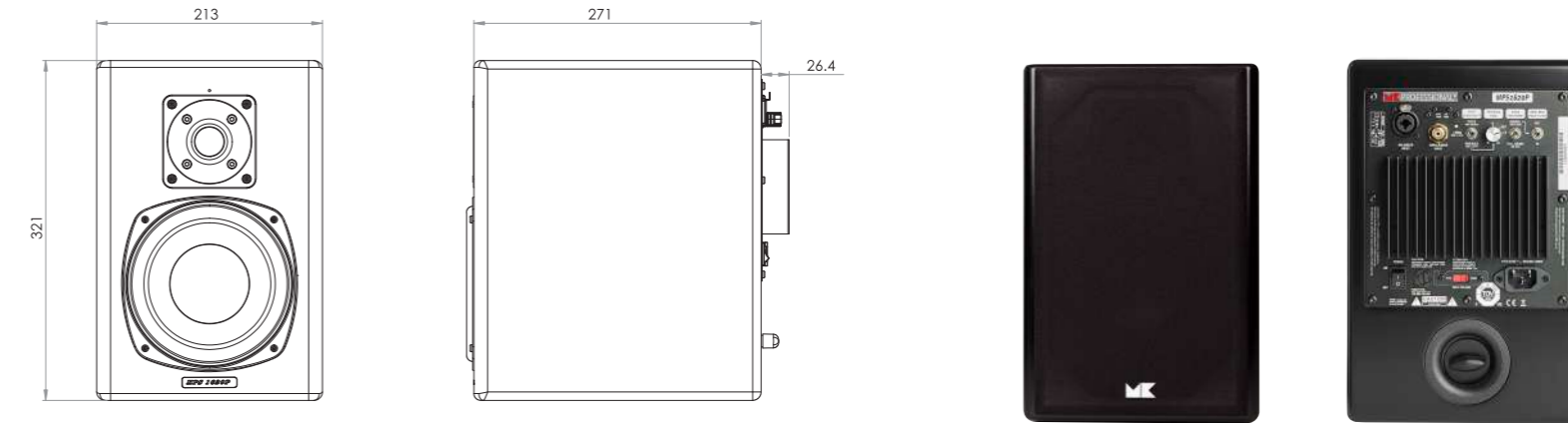

PRO  
SERIES



“

**I find the M&Ks very accurate,  
transparent and easy to mix on.  
But the most important thing is  
that they translate so well all the way  
to the end user”**

*Eddie Simonsen*

*Mainstream Studios*

*Supervising Sound Editor, Sound Designer & Rerecording Mixer*



“

**It's the best subwoofer I've  
encountered in two decades  
of reviewing”**

*David Vaughn  
Sound & Vision May 2022*







## X15+ Subwoofer



M&K Sound, inventors of the first powered subwoofer back in 1973, has produced its first ever 15-inch subwoofer. With an extraordinary 1,400-watts of onboard peak power, care of a Danish-built ICE Class D amplifier module, and a frequency response dipping to a subterranean 16 Hz, the new flagship subwoofer boasts M&K's legendary and distortion-busting push-pull dual-driver configuration. With a well-earned THX Certified Dominus badge, confirming that the sub can produce the required sound pressure levels (SPL) and reference audio in rooms of up to 6,500 cu ft, the X15+ represents the ultimate in home cinema bass performance. Surely the subwoofer to level all other subwoofers.

Frequency Response..... 16-200 Hz. (Average Response in Room +/- 3 dB)  
 Frequency Roll Off ..... THX EQ. 16 Hz. (-6 dB 20 Hz Nearfield )  
 Frequency Roll Off ..... Anechoic EQ. 16 Hz. (-6 dB 20 Hz Nearfield )  
 Variable Low Pass Filter ..... 40-125 Hz. Continuesly Variable / 4th Order  
 Low Pass Filter Bypass ..... 40-200 Hz. No Low Pass  
 Fixed 80 Hz Filter ..... Yes. (Equivalent to THX 80Hz Ref Low Pass)  
 Phase Control ..... 0 - 180 deg. Continuesly Variable  
 Line level input/output ..... 2 x RCA phono. Left / Right - input / output  
 Line level input/output ..... 2 x XLR. Left / Right - input / output  
 Amplifier type ..... Analog input / switch mode power output  
 Drive unit ..... 2 x 15". Extra Long Throw  
 System Principle..... Push Pull. Sealed enclosure  
 Amplifier Power output RMS..... 700 watt. <0.5% THD at 300W into 4 ohms  
 Amplifier Power output Peak ..... 1400 watt  
 Standby Power Consumption ..... 0.5 watt. 120W Average, 800W Max  
 Headroom Limiter Maximizer..... Yes. (Dynamic driver excursion control)  
 Auto Power detect on/off..... Yes  
 Finish..... Satin Black  
 Dimensions ..... H x W x D. 32.8 x 20.3 x 18.1" / 83.3 x 51.5 x 46.0 cm  
 Weight ..... Netto 134.7 lbs / 61.1 kg  
 Manual ..... Yes. Safety Manual included in packing  
 Accessories ..... Yes. Gloves, US/EU Power cords, Rubber Feet

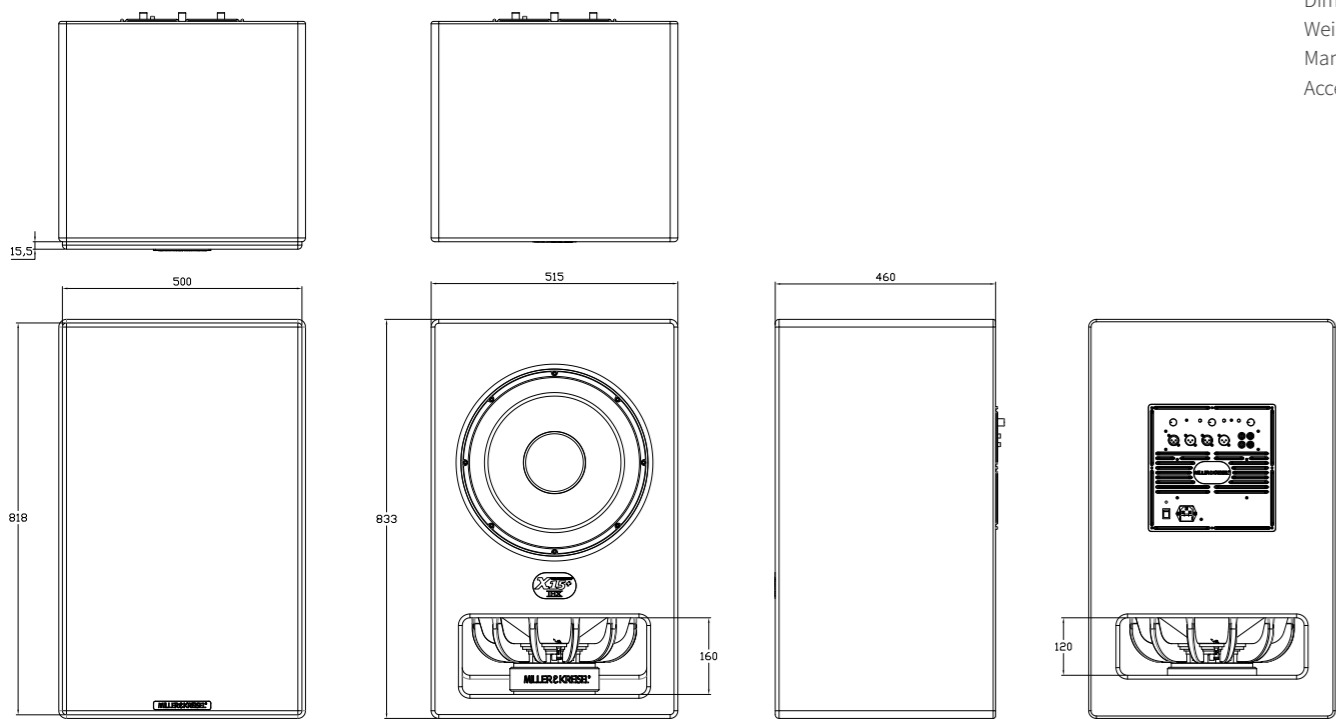

**M&K audio engineers are among the world's best, and passing THX rigorous standards for audio certification means passing hundreds of tests.**

**M&K can be proud of this accomplishment, and audio enthusiasts everywhere will be pleased with the extraordinary pure and powerful output of these superb subwoofers.”**

*Steven Martz  
 Vice president of global technology,  
 THX Ltd - 2021*

X+  
 S  
 E  
 R  
 I  
 E  
 S



## X12+ Subwoofer



The new X12+ subwoofer replaces the former X12. M&K Sound's expert engineering team has added numerous upgrades to the new product, including a 600-watt RMS and 1,200-watt peak output, redesigned woofers with 30% larger voice coils and magnets, and an alluring new design aesthetic of cleaner lines and discreet curved edges. The X12+ offers ultra-low distortion with M&K's signature push-pull coupled drivers and THX Certified Ultra status confirms reference performance in large home cinemas of up to 3,000 cu ft. While the M&K X+ Series subwoofers can produce earth-shaking response on multi-channel film audio sources, they have also been praised extensively by the AV press for their light-touch sensitivity on music sources and ability to reproduce atmospheric subtleties with absolute control and dexterity.

Frequency Response..... 18-200 Hz. (Average Response in Room +/- 3 dB)  
 Frequency Roll Off..... THX EQ 18 Hz. (-6 dB 20 Hz Nearfield )  
 Frequency Roll Off..... Anechoic EQ 18 Hz. (-6 dB 20 Hz Nearfield )  
 Variable Low Pass Filter..... 19 Hz. Continuously Variable / 4th Order  
 Low Pass Filter Bypass..... 20 Hz. No Low Pass  
 Fixed 80 Hz Filter..... Yes. (Equivalent to THX 80Hz Ref Low Pass)  
 Phase Control..... 0 - 180 deg. Continuesly Variable  
 Line level input/output..... 2 x RCA phono. Left / Right - input / output  
 Line level input/output..... 2 x XLR. Left / Right - input / output  
 Amplifier type..... Analog input / switch mode power output  
 Drive unit..... 2 x 12". Extra Long Throw  
 System Principle..... Push Pull Sealed enclosure  
 Amplifier Power output RMS..... 600 watt. <0.5% THD at 300W into 4 ohms  
 Amplifier Power output Peak..... 1200 watt  
 Standby Power Consumption..... 0.5 watt. 110W Average, 700W Max  
 Headroom Limiter Maximizer..... Yes. (Dynamic driver excursion control)  
 Auto Power detect on/off..... Yes.  
 Finish..... Satin Black  
 Dimensions..... H x W x D. 28.7 x 17.7 x 15.2" / 72.8 x 45.0 x 38.5 cm  
 Weight..... Netto. 101.2 lbs / 45.9 kg  
 Manual..... Yes. Safety Manual included in packing  
 Accessories..... Yes. Gloves, US/EU Power cords, Rubber Feet

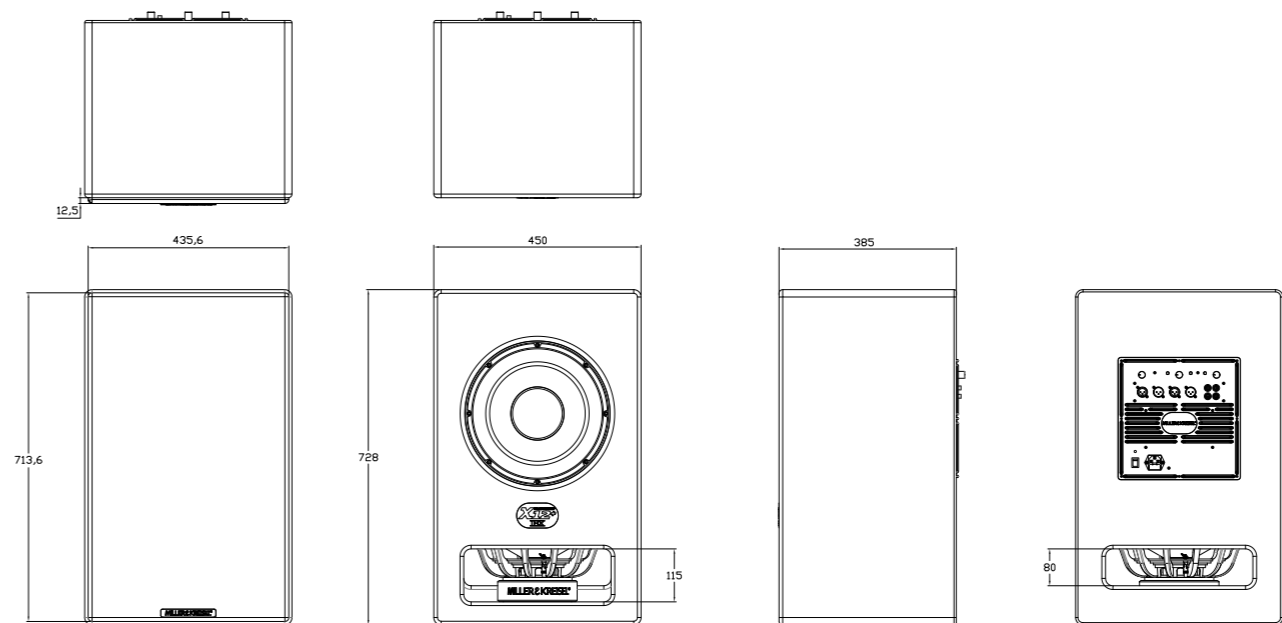

## X10+ Subwoofer



The most compact subwoofer in the X+ Series, M&K Sound's X10+ is still a titan in its own right. Benefitting from an enhanced Danish-built ICE Class D amplifier module and a massive 1,000-watt peak power output, the X10+ builds on the former X10 model with deeper, faster and louder designed carbon fiber woofer cones with ultra-high strength and rigidity for added power and distortion-free performance. The dual-driver, push-pull arrangement ensures listeners can enjoy 'feel it but can't hear it' bass frequencies flat down to 20 Hz. The X10+ carries a THX Certified Select ranking for guaranteed reference level movie audio in rooms of up to 2,000 cu ft.

Frequency Response..... 20-200 Hz. (Average Response in Room +/- 3 dB)  
 Frequency Roll Off..... THX EQ 20 Hz. (-6 dB 20 Hz Nearfield )  
 Frequency Roll Off..... Anechoic EQ. 20 Hz (-6 dB 20 Hz Nearfield )  
 Variable Low Pass Filter..... 40-125 Hz. Continuously Variable / 4th Order  
 Low Pass Filter Bypass..... 40-200 Hz. No Low Pass  
 Fixed 80 Hz Filter..... Yes. (Equivalent to THX 80Hz Ref Low Pass)  
 Phase Control..... 0 - 180 deg. Continuosly Variable  
 Line level input/output..... 2 x RCA phono. Left / Right - input / output  
 Line level input/output..... 2 x XLR. Left / Right - input / output  
 Amplifier type..... Analog input / switch mode power output  
 Drive unit..... 2 x 10". Extra Long Throw  
 System Principle..... Push Pull. Sealed enclosure  
 Amplifier Power output RMS..... 500 watt. <0.5% THD at 300W into 4 ohms  
 Amplifier Power output Peak..... 1000 watt  
 Standby Power Consumption..... 0.5 watt. 100W Average, 600W Max  
 Headroom Limiter Maximizer..... Yes. (Dynamic driver excursion control)  
 Auto Power detect on/off..... Yes  
 Finish..... Satin Black  
 Dimensions..... H x W x D. 25.5 x 15.7 x 13.4" / 64.7 x 40.0 x 34.0 cm  
 Weight..... Netto 88.4 lbs / 40.1 kg  
 Manual..... Yes. Safety Manual included in packing  
 Accessories..... Yes. Gloves, US/EU Power cords, Rubber Feet

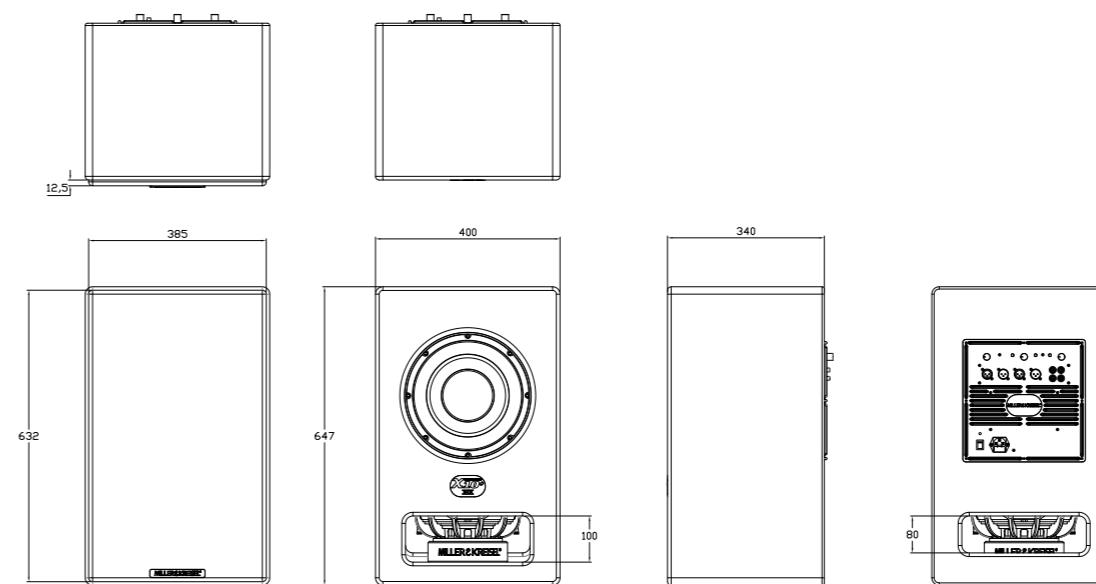

# X+ SERIES





“

**I've been installing systems for over 20 years and I can honestly say this 10" subwoofer truly outdoes itself and could easily compete with much larger subs"**

*Kaine Pritchett*

*Virtus Integration, May 2022*





## V15+ Compact Subwoofer

M&K Sound has overhauled the V Series of subwoofers to produce the lifestyle-friendly and small footprint V+ Series. Perfect for a large living room or gaming space, the THX Certified Ultra V15+ with massive single 15-inch driver can achieve home cinema audio reference levels in rooms of up to 3,000 cu ft. A power rating of 500 watts RMS - while also topping out at 1,000 watts peak - ensures that audiences can experience deep and accurate bass from a stylish, newly designed cabinet. The first time a 15-inch driver has been incorporated into the V family of subwoofers, the V15+ also introduces user control from a brand-new downloadable M&K App. Available from Apple Store and Google Play Store, owners of the V15+ can select EQ curves and adjust volume, crossover frequency, delay and phase from the comfort of their seated position.



THX Certification (with BLE) Auto EQ  
 Enclosure type ..... Sealed cabinet  
 Woofer ..... Single 15"  
 Power amp 500W RMS at 4 ohm / 1000W Peak  
 Frequency response ..... : 20 Hz to 200 Hz (+/- 2 dB in band tolerance)  
 Amp THD ..... Less than 0.5% at 500W into 4 ohms  
 Dimensions ..... : H 47.0 x W 47.0 x D 47.0 cm / H 18.5 x W 18.5 x D 18.5 inch  
 Weight ..... : 21 kg / 46.3 lbs  
 AC power consumption ..... 0.5W standby, 50W average, 300W max

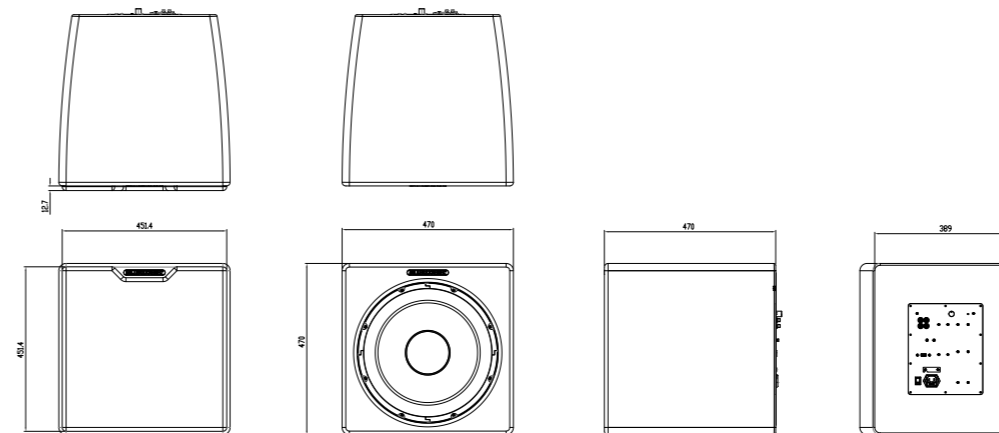

## V12+ Compact Subwoofer

The V12+ features a single 12-inch driver and has achieved THX Certified Select accreditation for powerful reference level bass in rooms of up to 2,000 cu ft. As well as sharing M&K App control with the larger V15+ model, the V12+ capitalizes on a newly designed reinforced paper cone driver in a sealed anti-resonant enclosure. A perfect subwoofer for midsize AV or living rooms, the V+ Series models all benefit from an overhauled design aesthetic of curved and tapered external housings, making them ideal for design-conscious environments. The V12+ Subwoofer is available in exquisitely painted White Satin or Black Satin finishes.



THX Certification (with BLE) Auto EQ  
 Enclosure type ..... Sealed cabinet  
 Woofer ..... Single 12"  
 Power amp ..... 400W RMS at 4 ohms / 800W Peak  
 Frequency response ..... : 20 Hz to 200 Hz (+/- 2 dB in band tolerance)  
 Amp THD ..... Less than 0.5% at 400W into 4 ohms  
 Dimensions ..... : H 39.5 x W 39.5 x D 39.5cm / 15.6 x 15.6 x 15.6 inch  
 Weight ..... : 16.3 kg / 35.9 lbs  
 AC power consumption ..... 0.5W standby, 40W average, 200W max

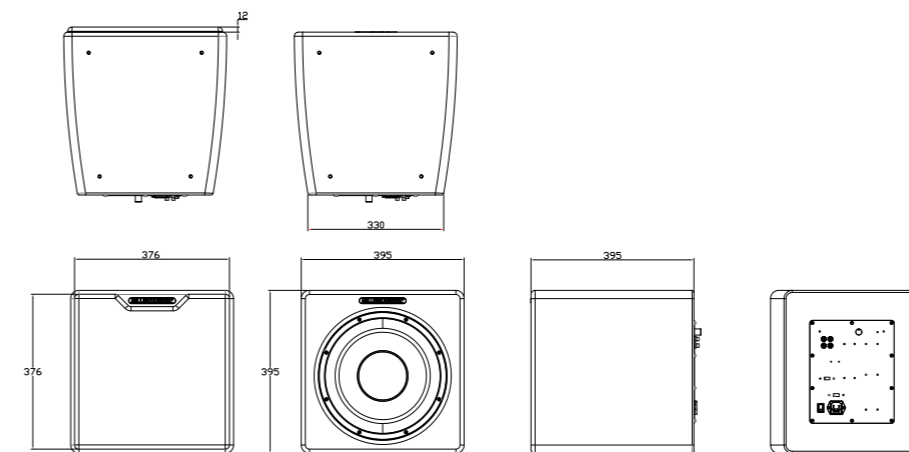

## V10+ Compact Subwoofer

Although sporting more compact front faceplate dimensions than its larger siblings at 13.5 x 13.5 inches, the V10+ Subwoofer is anything but underpowered. Boasting 300 watts RMS and 600 watts of peak power, the V10+ represents a powerhouse of deep bass performance in small entertainment rooms or snugs. Like the V15+ and the V12+, the V10+ carries a high-efficiency, precision-engineered Class D amplifier and M&K's proprietary 'front end' input stage, ensuring layers of realistic and impactful bass performance. Also consistent with the other models in the V+ Series, this smallest cuboid member of the family flaunts a newly developed magnetic grille for easy removal and can be ordered in White Satin or Black Satin finishes.



Enclosure type ..... Sealed cabinet  
 Woofer ..... Single 10"  
 Power amp ..... : 300W RMS at 4 ohms / 600W Peak  
 Frequency response ..... : 20 Hz to 200 Hz (+/- 2 dB in band tolerance)  
 Amp THD ..... Less than 0.5% at 300W into 4 ohms  
 Dimensions ..... : H 34.5cm x W 34.5cm x D 34.5cm / H 13.6 x W 13.6 x D 13.6 inch  
 Weight ..... : 10.3 Kg / 22.7 lbs  
 AC power consumption ..... : 0.5W standby, 30W average, 150W max

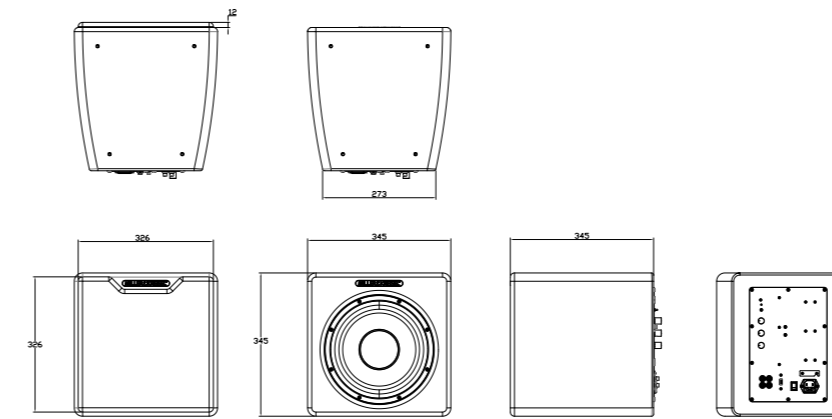

# V+ SERIES





## Movie 5.1 System

### It saves on space, not on audio quality!

Don't be fooled by the compact size of the Movie 5.1 System. It is not just recommended for young audio enthusiasts or home cinema beginners. This package of three K50 front speakers, two K40 surround speakers and one V8 subwoofer has been curated by M&K engineers to play back multi-channel movie soundtracks and games with both intense dynamics and immense scale. The Movie 5.1 System is capable of conveying everything from the quietest atmospheric vignettes to the loudest fast-paced action scenes. All the while, against competing music and sound effects, the K50 front center speaker is capable of delivering crystal clear dialogue every time.

With a slim depth of only 85 mm, the K50 front speakers can be easily mounted on the wall. Together with the K40T Tripole surround speakers and the V8 Movie active subwoofer, the six components form a powerful home cinema setup for your living room or office.

**The Movie 5.1 System is sold as a complete set and delivered in one box consisting of the following:**

- 3 x K50 speakers
- 2 x K40T Tripole® speakers
- 1 x V8 Movie subwoofer
- Wall brackets

#### K50

Nominal system impedance: ..... 4 ohm (Z-min 4.9 ohm)  
 Frequency Response: ..... 100-20Khz (average response in room +/- 2dB)  
 Frequency Roll Off: ..... 100Hz (-6dB 100 Hz near field wall mounted)  
 Crossover Frequency: ..... 1.8 Khz "Phase focused" (4th&2nd order)  
 Tweeter (shielded): ..... 1" Dome - Coated silk dome / Neodymium magnet  
 Woofer (shielded): ..... 4" Coated glass fibre  
 Power Handling: ..... 80 watt Long term IEC-268-5 (cycled input 100-20Khz)  
 Power Handling: ..... 50 watt (Rated IEC-268-5 (constant input 100-20Khz)  
 Recommended Amplifier Power: ..... 25-125 watt  
 Sensitivity: ..... 85 dB (Average SPL 2.83 Volt / 1mtr (on axis 200-10KHz)  
 System Princip: ..... Sealed enclosure  
 Connection: ..... Terminal gold plating (Screw for 5 mm cable / Banana)  
 Dimensions HxWxD: ..... 9.8 x 5.1 x 3.3" - 25 x 13 x 8,5cm (incl grill)  
 Weight: ..... 4.4 lb / 2.0 kg  
 Finish: ..... Black vinyl

#### K40T

Nominal system impedance: ..... 4 ohm (Z-min 4.6 ohm)  
 Frequency Response: ..... 100-20Khz (average response in room +/- 2dB)  
 Frequency Roll Off: ..... 100Hz (-6dB 100 Hz near field wall mounted)  
 Crossover Frequency: ..... 2.0 Khz "Phase focused" (4th&2nd order)  
 Tweeter (shielded): ..... 1" Dome - Coated silk dome / Neodymium magnet  
 Woofer (shielded): ..... 4" Coated glass fibre  
 Side drivers (shielded): ..... 2 X 3" (Polymer Coated Textured Paper)  
 Power Handling: ..... 80 watt Long term IEC-268-5 (cycled input 100-20Khz)  
 Power Handling: ..... 50 watt (Rated IEC-268-5 (constant input 100-20Khz)  
 Recommended Amplifier Power: ..... 25-125 watt  
 Sensitivity: ..... 85 dB (Average SPL 2.83 Volt / 1mtr (on axis 200-10KHz)  
 System Princip: ..... Sealed enclosure  
 Connection: ..... Terminal gold plating (Screw for 5 mm cable / Banana)  
 Dimensions HxWxD: ..... 7.7 x 7.8 x 4.8" -19.5 x 20 x 12,2 cm (incl grill)  
 Weight: ..... 6.5 lb / 2.9 kg  
 Finish: ..... Black vinyl

#### V8 Movie

Amplifier power ..... 150 watt RMS /250 watt peak  
 Frequency response ..... 30-200Hz +/- 2dB  
 Total harmonic distortion ..... >0.5% 150 watt, 4 ohm  
 AC power consumption ..... Standby/Average/Max 0,5/30/150W  
 AC Line Voltage ..... 100-240 VAC 50/60Hz 3,15A  
 LFE Input ..... L/R line level RCA  
 LFE Passthrough output ..... L/R line level RCA  
 Low pass filter ..... 60-200 Hz Continuously variable  
 Phase ..... 0-180 deg : Continuously variable  
 Volume ..... Continuously variable  
 Dimensions HxWxD ..... 13.3 x 10.3 x 11.4" / 337 x 260 x 290 mm  
 Weight ..... 24,3 lbs / 11,0 kg  
 Finish ..... Black vinyl





“

**Whether it's working in a big studio or out of my studio at home, I always get consistent results with the M&Ks and that's a big big plus for any speaker system”**

*Frank Marrone, Technicolor  
Award Winning Sound Re-Recording Mixer*





# Rear panels - dimensions for brackets

S300

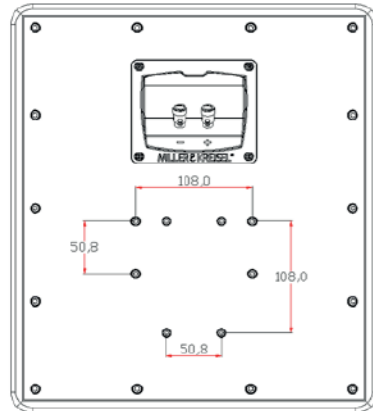

S300T

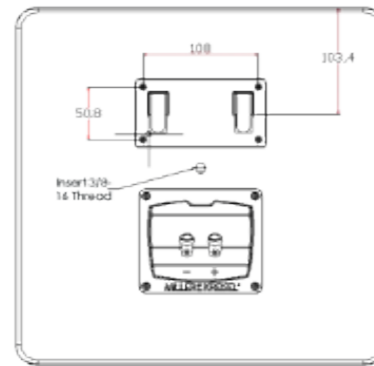

MP300

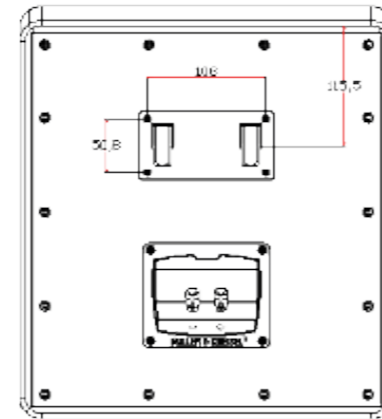

LCR950

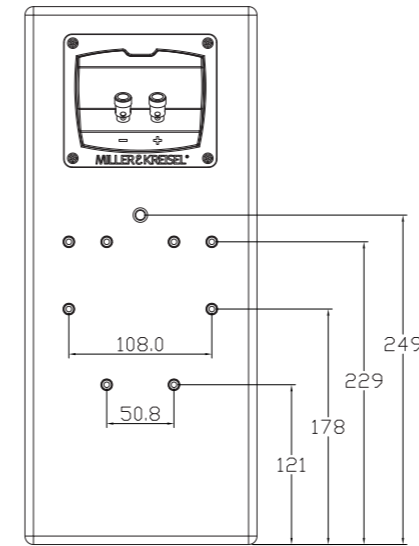

MP950

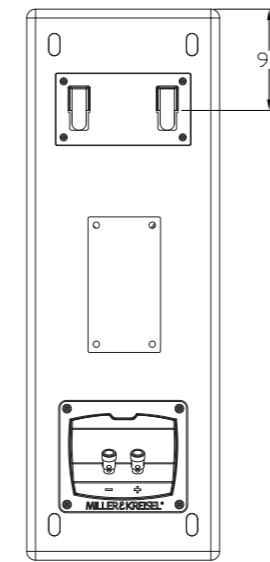

LCR750

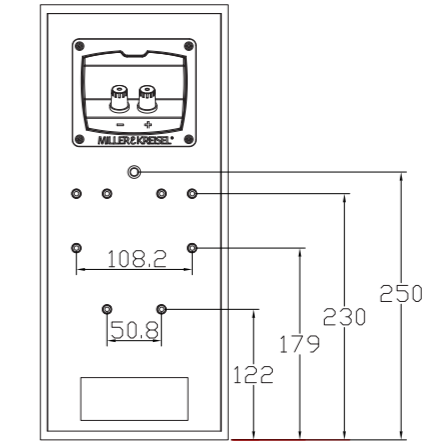

SUR55T

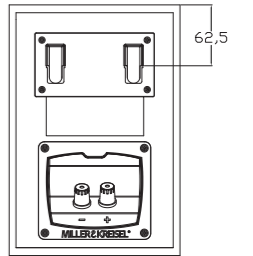

S150

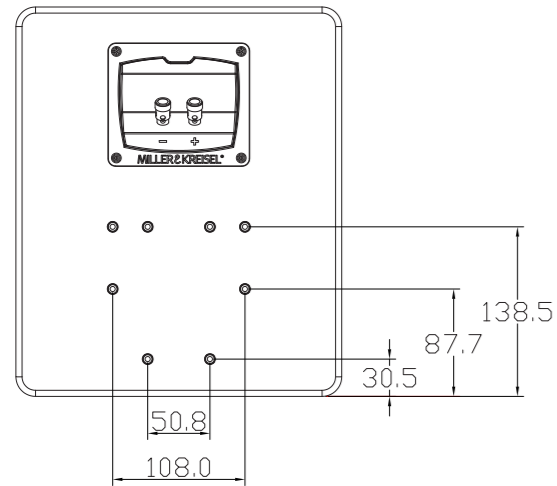

S150T

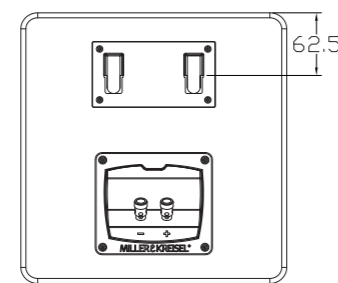

MP150

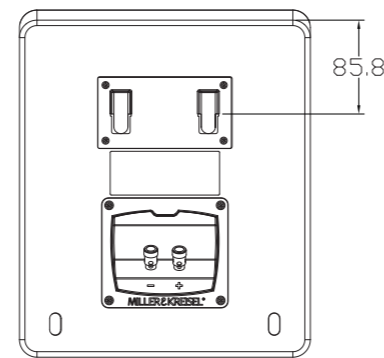

M70

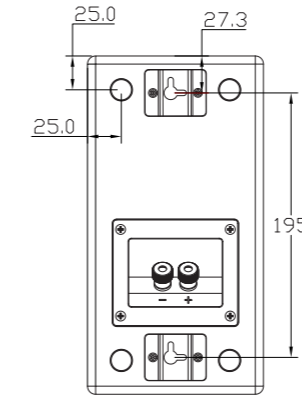
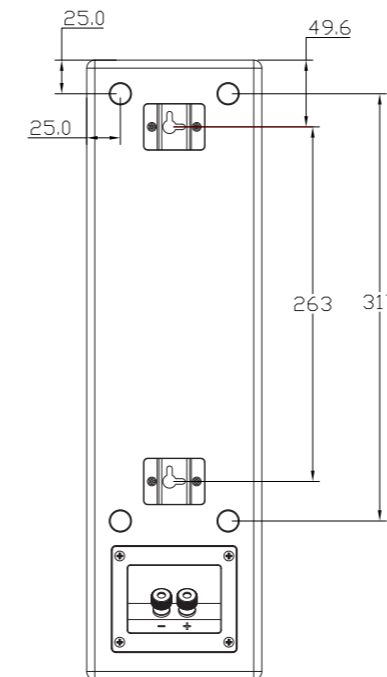

M40T

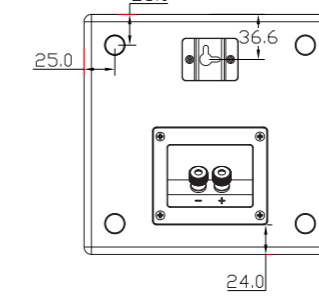

D85

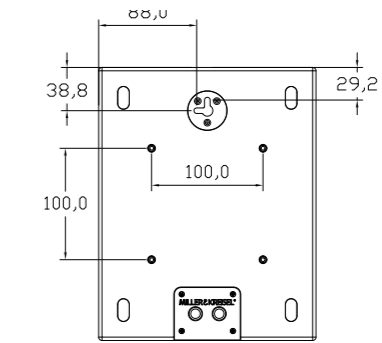

M90

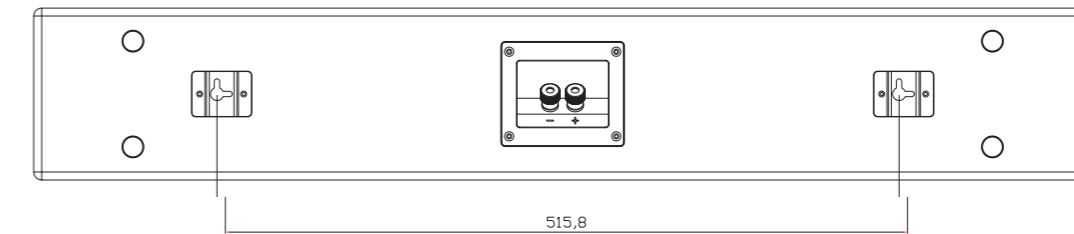

750C

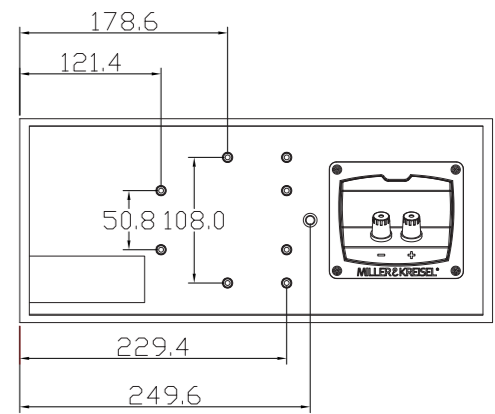

D95

