

A bundle of blue and yellow cables is shown orbiting the Earth from space. The cables are curved, following the curvature of the planet. The Earth's surface is visible below, showing blue oceans and dark landmasses. The background is the blackness of space.

GREAT CONNECTIONS

**SUPRA<sup>®</sup>Cables**  
MADE IN SWEDEN  
by JENNING TECHNOLOGY



### Legacy

Prior to 1976, speaker cables were just cables, often plain electrical cords similar to house-hold lighting flex, up to 2.5mm at most. Then came Supra...

It started with Supra Classic 2.5mm, a huge step up which shook the Hi-Fi world and from thereon, many followed our inventive ideas. Supra has won an impressive number of awards all over the world often in comparison with more expensive competitors.

After our trend setting introduction in 1976 and our serious approach to Hi-Fi interconnects, Supra has contributed with numerous products e.g. LoRad, Sword, and Ply, to the latest Cat7+, USB and ground breaking Quadrax. And, still there are new products just waiting to be launched.

### Concept

The Supra concept, or perhaps more correctly, the Supra philosophy is best described as plain and simple No-Nonsense-Design.

All products should be manufactured from parts meeting the highest audible and measureable quality standards.

- The products should be innovative and derived from established science principles.
- We manufacture in our own dedicated production facilities, constantly monitored by our certified quality staff, here in Ljungskile, in Sweden!



*Visit our factory*

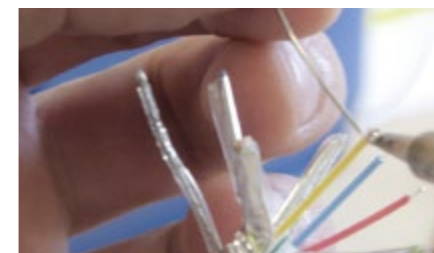

### Manufacturing

We have chosen to produce in proprietary facilities in Sweden. By investing in this, we control the entire process and can guarantee the top notch Supra quality we are renown of. Further it allows us to efficiently implement improvements, fine tune the manufacturing process and shorten lead time. Our expansion plans include increasing our production capability by a further 1500 sqm.

### Quality

All cables are subject to the highest level of scrutiny and is measured manually using modern and advanced test equipment. The cables are marked with batch number allowing us to back trace time, parts and personnel.



*Please join us on Facebook and Twitter*



# Tommy Jenving 1945-2011

**Tommy Jenving**, founder and CEO of Jenving Technology AB, passed away 11 November 2011.

He was an innovator, inventor and entrepreneur. Further, he was a very rational intellectual and considerate human being whose ingenuity formed the unique Supra design and solved many technical problems. The SUPRA organisation will continue to manage his legacy and strive to make both him and our customers proud of our products.

Team SUPRA Cables  
Jenving Technology AB,  
Sweden



Tommy Jenving  
Arken Award for Lifetime Achievement

# HDMI



## INDEX

HDMI & DVI  
PAGE 6 - 9

LORAD  
PAGE 10 - 15

SPEAKER CABLES  
PAGE 16 - 27

INTERCONNECTS  
PAGE 28 - 43

INSTALLATION  
PAGE 44 - 49

PRODUCT INFO  
PAGE 52 - 70



# HDMI & DVI

## HDMI & DVI

### Highest bandwidth

The bit rate surpasses all previous picture resolutions and now reaches 2160p / 4K Ultra HD format (UHDTV) and supports a minimum resolution of 3840 \* 2160 pixels. The demands from the new picture resolutions and sound formats are enormous and challenge both materials and design of the cables. Supra continues to work in the forefront of digital video technology and has developed two brand new digital cables as always according to our No-Nonsense Design concept. We call them HD5 and HD7.

### Design

HD5 and HD7 consists of 5 and 7 twin pairs, individual shielding per cable and dual screens for each pair, for best noise suppression and highest bandwidth. In practice, we consider the triple screen design to be the only effective way to transmit high frequency signals "without being prone to external interference.

### 30m HDMI

HD5 has evolved into a cable that, after very thorough testing, now connects compatible equipment at an assuring 1080p @24fps up to 30 metres! This makes SUPRA a world leader for high bandwidth HDMI cables and delivers astonishing performance at a moderate price. Did anyone say No-Nonsense?

### DVI Dual Link

HD7 is a HD5 with an additional pair of conductors for the purpose of high bandwidth for computer screens. Screen resolutions of 3840\*2400 @33Hz, 2560\*1600 @60Hz and 2560\*1440 @60Hz, on new generation >27inch screens, set new standards of both picture quality and cable design. DVI Single Link provide for resolutions of 1920\*1200 @60Hz.

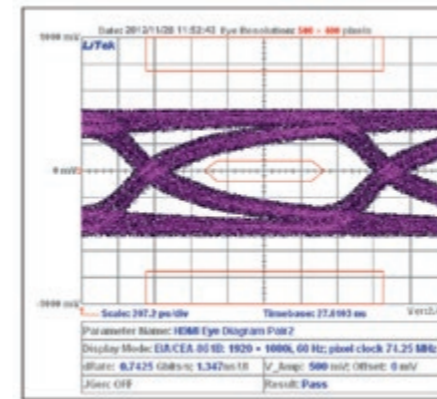
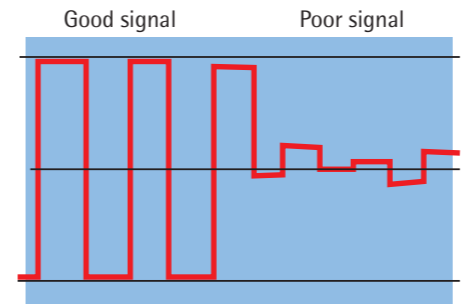

Approved Eye-pattern diagram; 20m SUPRA HDMI.

## HDMI

### High resolution picture and sound

We often meet scepticism when we talk about HDMI cables. "Does it really matter?" "I mean, it's only a data stream?"

Yes, it is a stream of digital bits. Yes, it does matter. Unfortunately there is an intermediate state before the signal is so corrupt it cannot be read and blanks out. Many claim that if the screen shows, the signal is good enough. There is circuitry in the receiver which tries to repair broken data stream by buffering and error correction, but this is based on best possible estimates and is not necessarily what was sent. You might experience sync problems (delays), distorted colorations, insufficient blackness, noise and unexplainable audible pops during which the hardware is working overtime trying to repair the fragile bitstream.

Do your precious hardware the best possible favour you can by connecting it using SUPRA HDMI cables and both you and your equipment will fully enjoy the show.

### Colours

- Anthracite
- Ice blue
- White

## HDMI

### Features & benefits

- Transmits today's challenging formats flawlessly
- Future proof - Meets today's HDMI standard and known requirements of tomorrow.
- Sturdy design - Withstand the normal installation abuse.
- 23AWG leads - For minimum losses.
- Triple screen technology - Provides for long distance clearance hence freedom of installation with maintained signal integrity.
- Made in Sweden, three step quality plan - Unsurpassed quality and reliability.



Item	Mechanical Specifications											Electrical Specifications					
	Application Examples	Standard	Cable	Cross. Area (mm <sup>2</sup> /AWG)	Wire Material	Insulation	Inner Screen Coverage	Comm. Conduct.	Outer Screen Coverage	Jacket	Flam Retard. Halogen Free	Ext. Size (mm)	Weight (g/m)	R (Ω/km)	C (pF/m)	Imp. Z (Ω)	Velo. Factor
HD5	HDMI & DVI-D 18+1	High Speed with Ethernet	Single-link	0,26 / 23	Solid OFC	PE	Alu/PET Foil, 100%	5 x AWG26 PE	Alu/PET foil & braid 100%	PVC	No	Ø9.5	106	82	42	100	0.8c
HD5/H	DVI-D 18+1			5xTMD5						PE	Yes, see p45						
HD7	DVI-D 24+1	Digital Visual Interface	Dual-link	0,26 / 23						PVC	No	Ø11	142				
HD7/H				7xTMD5						PE	Yes, see p45						

Additional product information available in the final section

Additional product information available in the final section



## HDMI MET-S/B

The SUPRA HDMI MET-S/B (Metal connector straight/bent) is the alternative for in-wall installation in 20mm pipes and 25mm conduits. The unique, patented, design allows the contact housing to be removed prior to installation without compromising the contact connectivity. The housing is easily removed by simply undoing two screws. There are two versions of housing supplied: one straight and one bent, to provide a choice of connection angle.



When it comes to performance, there is no down-specification by choosing the most convenient SUPRA HDMI Cable and is therefore available up to 30m length.

## HDMI Extender

The HDMI Extender is built around highly sophisticated circuitry allowing support of the latest HDCP version 1.2 (High Bandwidth digital Content Protection). It is compatible with all HDMI hardware available today. Further it supports CEC (Consumer Electronic Control). The application for CEC is called Simplink for LG, Bravia for Sony and Anynet+ for Samsung, among others. It is a protocol allowing one remote control to operate up to ten units, provided they all are compatible to CEC.



The HDMI Extender chassis in stylish sandblasted aluminium provides for maximum noise suppression.

The kit consists of:

- 1 pc Transmitter
- 1 pc Receiver
- 1 pc AC-adaptor
- 1 pc User's guide

HDMI and network cables are sold separately.

### Require HDMI cable length >30metre?

The main HDMI limitation is cable length. If longer cables than 30metres are required, amplification is needed. Standard A/V equipment is designed for shorter distances and does not provide sufficient signal strength and stability over 30metres. SUPRA HDMI Extender uses a pair of network cables (such as Supra Cat7+) and enables the transmitting of FullHD (full high definition picture 1080p @24fps), 3D and all of today's high resolution audio formats such as DTS-HD, DTS-Master Audio, Dolby TrueHD and LPCM 7.1 (Digital Theater System Inc., Linear Pulse Code Modulation) over 100metres while still allowing substantial bandwidth headroom and noise immunity.

## DVI-D

DVI (Digital Visual Interface) is a standard for digital picture transmissions between e.g. computers, screens and projectors. SUPRA DVI is designed to transmit signals up to 30metres. The cable is equipped with 24K gold plated connectors and a contact housing made of aluminium to further avoid signal degradation which it is possible to remove while installing. There are two versions of DVI; Dual and Single Link. They perform as follows:

- Dual Link: 3840\*2400@33Hz (WQXGA<sup>1</sup>), 2560\*1600@60Hz and 2560\*1440@60Hz (WQXGA<sup>1</sup>)
  - The contact consists of 24+1 gold plated connectors
  - Single Link provide for resolutions of 1920\*1200@60Hz (WUXGA<sup>1</sup>)
  - The contact consists of 18+1 gold plated connectors
1. Refer to proper computer dictionary for various screen resolution description and their respective designation.

## HDMI-DVI and DVI-HDMI adapters

Occasionally an adapter is needed to connect the numerous contact hardware combinations the modern integrated multimedia equipment offers. Choose from HDMI to DVI or, if required, the opposite. All stylish, plated with 24K gold and as always keeping signal integrity strong. Simply SUPRA.



## HDMI-DVI

The Supra HDMI-DVI cables connect computers, media players and screens for video and graphic images. SUPRA HDMI-DVI maintains the signal integrity up to >30metres cable length and allows transmissions in both directions i.e. the cable is bi-directional. It is available in two versions; HDMI-DVI and HDMI-DVI MET-S/B.

- HDMI-DVI is supplied with a moulded HDMI contact at one end and a removable DVI housing (the housing can be removed, but the contact block cannot). Provides for maximum resolution of 1920\*1080P@60, 30 and 24fps (Hz).
- HDMI-DVI MET-S/B is supplied with a removable HDMI contact housing as described in the previous section (page 8), and a removable DVI contact housing as described above. Provides for maximum resolution of 1920\*1080P@60, 30 and 24fps (Hz).

## HDMI SA 90+ and SA 90- adapters

Whenever a tight turn 90 degrees left (SA90-) or right (SA90+) is required, there is always a stylish, 24K gold plated adapter available from SUPRA Cables maintaining signal integrity.



# POWER

## SUPRA LoRad

LoRad means LOW RADIation and minimize both electrical and magnetic fields.

LoRad protects both from fields radiating from the cable and pick-up of surrounding noise fields, e.g. wireless and mobile phones, radio broadcasts, etc.

LoRad MkII is a development of the Lorad concept, now with even improved shielding properties, flexibility, bend-resistance and strength.



### TRY!

You can easily test the power cord radiation with AC field sensor.

Hold the sensor tip to a cable and if it lit, the cable radiates an electrical field. The cable need to be connected to a live wall socket.



Now, try the SUPRA LoRad instead and you will find no indication.



## LoRad *Mark II*

LoRad means LOW RADIation and minimize both electrical and magnetic fields. LoRad protects both from fields radiating from the cable and pick-up of surrounding noise fields, e.g. wireless and mobile phones, radio broadcasts, etc. LoRad MkII is a development of the Lorad concept, now with even improved shielding properties, flexibility, bend-resistance and strength.

The radiation is lowered by means of two techniques. First the shield minimizing the alternating electrical fields from the cable. It also minimizes the RF pick-up (Radio Frequency). The magnetic fields are cancelled by twisting the conductors in a short pitch.

The benefits are cleaner sound, pronounced transients and an improved 3D soundstage. We also hear customers describe more detailed sound and we are not surprised. If your equipment is installed using SUPRA cables, the noise floor is generally suppressed by several dB, allowing more of the content to be revealed. Low radiating cables is also increasingly important from a health point of view. Science has proven that alternating magnetic fields affects cell growth.

The biggest differences between Lorad MkII and the old Lorad cable, is that it is now based on SUPRA's unique Nylon screen concept. Semiconducting Nylon Screen provides improved shielding properties, bending strength, environmental immunity, higher tensile strength and less microphonic effect. The Nylon screen is connected with a drain-wire. We have tested and evaluated all known types of screens for making such a good cable as possible. SUPRA's semi-conductive Nylon screen was the only one that passed the safety requirements and, moreover, its shielding properties was best in test. LoRad MkII is tested and certified by Intertek Sweden, meeting the European safety regulation HD21.5 S3.

LoRad is the only shielded cable meeting the European safety regulation HD 21.5 S3. The cable must be connected to a wall socket with a ground terminal for the full LoRad effect.

#### Applications:

- Hi-Fi and studios
- Medical equipment
- Laboratories
- EHS (electro hypersensitivity)
- Noise critical installations

#### Selected customers:

- Swedish National Laboratory of Forensic Science, SKL
- Swedish Air Force (JAS Project)
- Hospitals
- A majority of European air traffic control towers

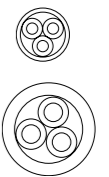

3x1,5mm<sup>2</sup>  
3x2.5mm<sup>2</sup>



Item	Mechanical Specifications								Electr. Specifications				
	Cross. Area (mm <sup>2</sup> /AWG)	No. Cond.	No. Wires	Wire Dia. (mm)	Wire Material	Insulation	Screen Coverage	Jacket	Ext. Size (mm)	Weight (g/m)	R (Ω/km)	Voltage Nom. (V)	Current Nom. (A)
LoRad 3G1.5	1.5 / 15	3	90	0,15	Tin plat.	2 layers	Semi-Cond.	Heat Et Ageing	Ø8,5	103	10,8	250	10
LoRad 3G2.5	2.5 / 13		320	0,10	OFC	PVC	Nylon, 100%	Resitant PVC	Ø11	170	6,8		

Additional product information available in the final section

# LoRad

## LoRad Mains Block with Aluminium Housing

Radiation Free, fully shielded in Aluminum with Non-Intrusive Filtering & Multi-way Surge Protection (SP-models). Available for American, British and European standards.

A shielded mains distribution block in Aluminum with surge protection. Free from noise deriving from a variety of noise fields from e.g. cell phones, DECT phones, dimmers and many other domestic electrical equipment? SUPRA MD is a sound and performance enhancing mains distribution strip, containing a proprietary SUPRA NIF, Non-Intrusive Filtering circuitry, providing a mild noise and radio frequency filtering that will not slow down or mute the dynamics from your Hi-Fi audio system. The conscious Hi-Fi enthusiast connects the Supra MD mains distribution strip only to wall sockets with earth terminal using Supra LoRad mains flex (optional).

- Radio frequency interference reduced by 40dB!
- Internal wiring of 2.5sqmm oxygen free copper leads
- Supports a staggering up to 3680W of continuous power!
- Protects you and your Hi-Fi audio system from harmful noise fields and radiation!
- Suitable for wall mounting



### ● SUPRA NIF Transient Filter

A Non-Intrusive Filtering circuitry, providing a mild noise and radio frequency filtering that will not slow down or mute the dynamics from your Hi-Fi audio system. It is developed by Ben Duncan Research in UK.

### ● Multi-way Surge Protection

When other manufacturers stop at one-way protection, i. e. only between the live and neutral lead from the power source, Supra goes all-in and offer a full three-way protection required to protect your HiFi audio system from e.g. a nearby lightning strike. The conscious HiFi enthusiast connects the Supra MD mains distribution strip only to wall sockets with earth terminal using Supra LoRad mains flex (optional).

## LoRad Mains Block Mk II

### MD06-US

NEMA-15 sockets according to American standard. Input connector according to IEC-320. 15 amp fuse and NIF filter.

### MD06-US/SP

As MD06-US and in addition the SUPRA multi-way surge protection



### MD06-BS/SP

UK 13A sockets according to British standard BS1363/A. Input connector according to IEC-320. NIF transient filter and the SUPRA Multi-way surge protection

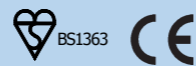

### Hazard!

Supra provides this safety warning when arranging a grounding point other than provided in approved power outlet sockets! Grounding, by means of connection to radiators or any other interior fitting supposedly connected to ground, is absolutely FORBIDDEN as it could potentially be hazardous to yourself or any other resident!



### Note!

SUPRA Mains Blocks must be connected to a ground terminal socket for the various protections and filters to become active.



MD06-EU

MD06-EU/SP

# LoRad

## Mains Block Mk III

The new EU Mk3 mains blocks are greatly improved. Even better connectors, filter and surge protection. All parts are made in Germany and Sweden. Assembling in the Supra factory, Ljungskile, Sweden.

## Not enough power?

MD08-EU/SP, MD10-EU/SP  
- The complete solution

Modern multimedia systems often consists of many units and they all require power. The MD08 and MD10 include eight/ten Schuko EU sockets and is sufficient in most cases.

- SP - SUPRA Multi-way Surge Protection
- NIF - Non-Intrusive Filtering



A set of stainless steel brackets for wall mounting is included



16A

## LoRad Mains Block Mk III

### MD06-EU

Radiation Free, with Non-Intrusive Filtering. 6 Schuko EU sockets. Input connector according to IEC-320. 10 amp ceramic fuse.

### MD06-EU/SP

As above and in addition the SUPRA multi-way Surge Protection. Suitable Mains Flex cords for MD06 is LoRad CS-EU (refer to page 14 for details).

### MD08-EU/SP

Radiation Free, with Non-Intrusive Filtering and SUPRA Multi-way Surge Protection. 8 Schuko EU sockets. Input connector according to IEC-320 16A.

### 16 amp+ground sockets!

Suitable Mains Flex cords for MD08/10-EU is LoRad CS-16-EU (refer to page 14 for details).

### MD10-EU/SP

Radiation Free, with Non-Intrusive Filtering and SUPRA Multi-way Surge Protection. 10 Schuko EU sockets. Input connector according to IEC-320 16A



MD10-EU/SP

Item	Mechanical Specifications							Electr. Spec.			
	Filter Type	Surge Protection	Connectors, High Voltage	Pin Material	Chassis	Fuse	Ext. Size LxBxH (cm)	Voltage Nom. (V)	Current Nom. (A)		
MD06-BS/SP	NIF Transient Filter	3-way	MCH-10	->	6 x BS1363/A	Brass	Earthed Aluminium	-	47x9,5x5,5	240	13
MD06-EU		-	MCH-10	->	6 x Schuko, EU/Fr						
MD06-EU/SP		3-way	MCH-10	->	6 x Schuko, EU/Fr			10 A	38x9x5,3	110	15
MD06-US		-	MCH-10	->	6 x Nema-15			15 A	32x8,5x5		
MD06-US/SP		3-way	MCH-10	->	6 x Nema-15			-	36x8,5x5	240	16
MD08-EU/SP		-	MCH-16	->	8 x Schuko, EU/Fr			-	54x9x5,3		
MD10-EU/SP	-	MCH-16	->	10 x Schuko, EU/Fr	-	64,5x9x5,3	240	16			

Additional product information available in the final section

Additional product information available in the final section

# LoRad

## Shielded Mains Flex

### LoRad CS-EU

The European version is equipped with Schuko connectors. Available with straight & angled Schuko plugs. Fits in most countries in Europe except Denmark, Italy, Ireland and United Kingdom.

### LoRad 1.5 and 2.5 CS-EU/Angled

Shielded mains flex available in two dimensions, i.e. 1.5mm<sup>2</sup> and 2.5mm<sup>2</sup>, SW-10S connector according to IEC-320 and angled SW-EU/A plug. Max 10 Amp, both dimensions.



LoRad CS-EU/Angled



LoRad CS-EU

### LoRad 1.5 and 2.5 CS-EU

Shielded mains flex available in two dimensions, i.e. 1.5mm<sup>2</sup> and 2.5mm<sup>2</sup>, SW-10S connector according to IEC-320 and SW-EU plug. Max 10 Amp, both dimensions.

### LoRad 2.5 CS-16-EU

Shielded mains cable with inner conductors of dimension 2.5mm<sup>2</sup>, SWF-16 connector according to IEC-320 and SW-EU plug. Max 16 Amp



LoRad CS-16-EU



### LoRad 2.5 CS-16-EU/Angled

Shielded mains cable with inner conductors of dimension 2.5mm<sup>2</sup>, SWF-16 connector according to IEC-320 and angled SW-EU/A plug. Max 16 Amp.



LoRad CS-16-EU/Angled

### LoRad CS-BS

British standard BS 1363/A shielded mains cable. Only available factory terminated in 1.5mm<sup>2</sup> conductor diameter due to British Standard regulations.

### LoRad 1.5 CS-BS

Shielded mains cable with 1.5mm<sup>2</sup> diameter inner conductors, SWF-10 connector according to IEC-320 and MC-BS-plug.



LoRad CS-BS

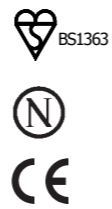

### LoRad CS-US

US standard, NEMA-15, also common in Asia. The plug meets hospital grade approval.

### LoRad 1.5 and 2.5 CS-US

Shielded power cord available in two dimensions, i.e. 1.5mm<sup>2</sup> and 2.5mm<sup>2</sup>, SWF-10 connector according to IEC-320 and SW-US-plug. Max 15 amp, both dimensions.



LoRad CS-US



SW-EU



SW-EU Angled

### SW-EU Male Plug

16A Schuko, European Standard. Gold plated pins. Accepts a cable dia. up to 11mm and cable area up to 2.5mm<sup>2</sup>.

### SW-EU/A 90-deg Angled Male Plug

16A Schuko, European Standard. Gold plated pins. Accepts a cable dia. up to 11mm and cable area up to 2.5mm<sup>2</sup>.



SWF-10S



SWF-16



SW-US NEMA



MCH10



MC-BS



### SWF-10S

Female cord connector, 10 amp, IEC-320 standard, gold plated connectors and suitable for SUPRA Mains Flex 1.5 and 2.5mm<sup>2</sup>.

### SWF-16

Female cord connector, 16 amp, IEC-320 standard, gold plated connectors and fit SUPRA Mains Flex 2.5mm<sup>2</sup>. Requires a 16 amp chassis connector and will not fit MCH10 below.

### SW-US

Male cord plug, 15 amp, Nema-15 US standard, gold plated connectors and suitable for cables up to 11mm.

### MCH10

Male chassis connector, 10 amp, IEC-320 standard and 10A ceramic fuse. Fits SWF-10/S above.

### MC-BS

Male cord plug, 13 amp, British standard, gold plated connectors and suitable for cables up to 11mm.

# LoRad

Grounded,  
Reconnectable  
Connectors,  
Audio Grade, Hospital  
Grade, Patented

### SUPRA LoRad SW Series

#### A Series of Patented Mains Plugs

SW is a series of mains plugs for 110-240V, safety approved Hospital Grade and Audio Grade. Sturdy design provides for reliability and long life. Accepts large cable diameter, up to 11mm. Easy to assemble, no loose screws, nothing to slip onto the cable before termination. Available for American, British and European standards.



Item	Mechanical Specifications					Electr. Spec.				
	Application	Cable Inlet	Standard	Conn. <Direction> Wall Socket	Conn. Equipment	Screen Connection	Voltage Nom. (V)	Current Nom. (A)		
LoRad 1.5 CS-EU	Earthed 250V	Straight x 2	EU/Fr	SW-EU	-> SWF-10s	Semi-Conductive Nylon/Carbon	250	10		
LoRad 1.5 CS-EU/A				SW-EU/A	-> SWF-10s					
LoRad 1.5 CS-BS	Earthed 110V	90-D/Straight	British	MC-BS	-> SWF-10s				13	
LoRad 1.5 CS-US				Nema	SW-US				-> SWF-10s	15
LoRad 2.5 CS-EU	Earthed 250V	90-D/Straight	EU/Fr	SW-EU	-> SWF-10s				250	10
LoRad 2.5 CS-EU/A				SW-EU/A	-> SWF-10s					
LoRad 2.5 CS-US	Earthed 110V	Straight x 2	Nema	SW-US	-> SWF-10s	15				
LoRad 2.5 CS-16-EU				Earthed 250V	90-D/Straight	EU/Fr	SW-EU	-> SWF-16		
LoRad 2.5 CS-16-EU/A	SW-EU/A	-> SWF-16								

Additional product information available in the final section

Item	Mechanical Specifications								Electr. Spec.						
	Male/Female	Connector	Cable Inlet	Standard	Pin Material	Conductor Connection	Cable Clamping	Max Cable Dia. (mm)	Mounting Hole (mm)	Voltage Nom. (V)	Current Nom. (A)				
SW-EU/A	Male	3-pole Cord Plug	Angled 90-D	EU & French	24K Gold Plated Brass	Screw	Screw	Ø11	-	250	16				
SW-EU			Straight							Nema	110	15			
SW-US	Angled 90-D	British	250	13											
MC-BS	Female	3-pole Cord Plug	Straight	International						Screw	Screw	-	-	250	10
SWF-10s														16	
SWF-16	Male	3-pole Chassis	-	IEC-320						Soldering	-	-	26,5 x 20	10	
MCH-10					10										

Additional product information available in the final section



# BEST

GOOD

## SUPRA Classic – The Original

Prior to 1976, speaker cables had no name, simply because no one actually knew about the massive impact cables had.

The average choice was 2x0.5 mm<sup>2</sup> or in rare cases, 2x0.75mm<sup>2</sup>, cables mainly used for connecting lamps and other plain house-hold electronics. Then SUPRA struck the Hi-Fi world with a staggering 2x2.5mm<sup>2</sup>! And, it is still a highly appreciated entry level speaker cable and has met new areas of use thanks to its formidable resistance to abusive environments. Tin plated.

BETTER

## SUPRA Ply – it's hip to be square

The square shaped design reveals the full potential of dynamics and transients of your Hi-Fi system. Further, it reduces interference and interaction distortion. Tin plated.

BETTER

## SUPRA Rondo – Twisted dynamics goes 'round

There are a few methods to cancel cable interference and twinning is one highly recognized and in fact the same reason why also LoRad power cords so elegantly cancel magnetic fields. The downside is torsion tension, a cable mechanics problem, which SUPRA solved and is able to produce with an interference cancelling short pitch, dynamic music handling and still flexible enough for in-wall installation. Tin plated.

BEST

## SUPRA Sword – The High End

When nothing but the best is good enough. Sword is a highly acclaimed, available also as interconnects, as a very "sound" cable choice thanks to its no-nonsense design delivering all high end parameters at just a fraction of the price in comparison and with SUPRA's typical neat appearance welcome in most reception rooms. Patented.

BEST

## SUPRA Quadrax – Multiple high ends

An exquisite speaker cable, the latest brilliant example of the SUPRA ingenuity. A totally new concept, possible to adapt to a number of wiring alternatives depending on your speaker set-up. Regardless of which, we promise you the sound of your life at this price level.

## Classic Series

The Classic series comprises flexible tin plated multi strand Oxygen-Free copper with 5N purity! This means that the copper purity must be better than 99.999%. In addition to the corrosion resistant tin plating, the insulation of a select grade chemically stable PVC further enhance the sonically benign tin surface over time. The tin plating contributes also to a much wanted skin-effect reduction and forces the electrons from disruptive "jumps" between the strand surfaces.

The Classic series is suitable for small/low power to high power systems or for long cable runs.

### Colours

- Anthracite
- Ice Blue
- White



### Classic 1.6

2x1.6mm<sup>2</sup> ■ ■ ■  
Typical applications: low powered, short length mid-powered or treble wiring in a bi-wired or bi-amplified Hi-Fi system.

### Classic 2.5

2x2.5mm<sup>2</sup> ■ ■ ■  
Typical applications: Mid powered, short length high-powered or both treble and bass wiring in bi-wired or bi-amplified Hi-Fi system.

### Classic 4.0

2x4.0mm<sup>2</sup> ■ ■ ■  
Typical applications: High powered, also intermediate lengths or bass wiring in bi-wired or bi-amplified Hi-Fi system. Maintained flexibility.

### Classic 1.6/H Halogen free

2x1.6 mm<sup>2</sup> ■ ■ ■  
Same as the regular Classic 1.6 but with fire retardant, halogen free, ECCOH-insulation. The cable is slightly stiffer yet easy-gliding insulation, perfect for in-wall installation.

### Classic 2.5/H Halogen free

2x2.5 mm<sup>2</sup> ■ ■ ■  
Same as the regular Classic 2.5 but with fire retardant, halogen free, ECCOH-insulation. The cable is slightly stiffer yet easy-gliding insulation, perfect for in-wall installation.

### Classic 4.0/H Halogen free

2x4.0 mm<sup>2</sup> ■ ■ ■  
Same as the regular Classic 4.0 but with fire retardant, halogen free, ECCOH-insulation. The cable is slightly stiffer yet easy-gliding insulation, perfect for in-wall installation.

### Mini 1.6

2\*1.6mm<sup>2</sup> □  
Economy version comprising fewer strands.  
Typical applications: low power, rear speaker.



Read more about fire retardant material, page 44.

### Classic 6.0

2\*6.0mm<sup>2</sup> ■ ■ ■  
Typical applications: High powered, also long lengths or bass wiring in bi-wire or bi-amplified Hi-Fi system. Still surprisingly flexible.

Note! The cables are directional. Refer to page 51 for additional information.

Item	Mechanical Specifications										Electr. Spec.	
	Cross. Area (mm <sup>2</sup> /AWG)	No. Cond.	No. Wires	Wire Dia. (mm)	Wire Material	Jacket	Ext. Size (mm)	Weight (g/m)	Flame Retard. Halogen Free	R (Ω/km)	L (μH/m)	
Mini 1.6	1.6 / 15	2	90	0.15	Tin Plated OFC	Heat & Ageing Resistant PVC	3.1x6.2	44	No	10.8	0.40	
Classic 1.6	204		3.6x7.3				65	Yes, see FRHF page 45	10.5	0.45		
Classic 2.5	322		4.8x9.6				108	6.8	0.55			
Classic 4.0	511		5.5x11.2				154	4.3	0.59			
Classic 6.0	756		No				2.9	0.59				

Additional product information available in the final section

## PLY Series

### A square thinking provides dynamics

#### 'A Logical and Progressive Design'

Audio cables' performance is initially determined by their loop resistance (R) & inductance (L) & shunt capacitance (C). For most speakers, R & L must be low, but capacitance value, C doesn't matter as speakers already act as large cap loads. But simply using larger wire makes R low, at the expense of an increasing ratio to L with musically unacceptable effects.

Ways to make inductance L low also with low resistance, include tapes, either stacked or arranged in ribbons. But these types are impractical to fit to nearly every speaker connector without discontinuities, & are stressed often unsightly when bends are required in real installs & also aren't suited to mobile uses. Litzing with multiple, insulated conductors is more practical, but quality Litzes are expensive and termination not easy. Other types are gross, like industrial pipes, unsuited to many domestic spaces. Simplistic fat conductors' rising impedance (due to L) of +6dB/octave is further raised by internal eddy currents causing 'Skin effect', like 'the square root of inductance', adding, +3dB/oct, to the L-reactance slope. For typical cable runs, net inductivity is such that performance in heavy plain conductors is measurably affected with steady signals just above 1kHz.

Cables with copper or silver stranded conductors suffer from complex oxidation. The semi conductive 'diodes' between the strands aren't seen by steady tests, but look like a high capacitance to music signals. This causes energy storage/release cycles, that regular tests miss, yet which is audible with music. This problem is also describable as the electron flow being 'trapped' inside strands & twisting away from the direct route.

SUPRA PLY is a large section, low resistance cable, overcoming skin effect & transient distortion, using pure tin plating. Tin melds to copper without any diodic barrier, & also protects the copper from common corruptions - ideal for outdoors & 12 volt. Most audiograde cables' conductors are damaged by contamination, by plastic out-gassing, from the impure atmosphere, & liquid spills. Some are protected but only by a thin coating that'll one day crack with use and age. Neatly, oxidation forming on Ply is sonically benign.

Other advantages when installing, PLY's rectangular conductor is readily circularised for insertion into receptacles of most regular connectors. Square outer profiling suits most housings too - unlike ribbons, tapes & litzes. PLY is readily coiled, more like thinner, basic cables - making it friendly in temporary setups.

#### Demoing the Difference

Unlike some audio products, benefits of SUPRA PLY are readily shown by repeatable measurements. Fig.1 using a swept sine wave shows progressively increasing losses >1kHz for all cables, caused by L & skin effect, ranging to 10dB at 20kHz - ultrasonic sounds do matter [3] ! Ply's low-loss behaviour for hf audio (incl. bass transients), is evident. Figs. 2 are time domain 'scope pics, showing typical dynamic/damping differences with a square wave. After transients, SUPRA's Ply restrains the peaking & accelerates the signal's return to 0 volts at the speaker end. Peaking in wide spaced cable shows limp damping & hf loss, because it has high L & low C, the opposite of what's required to drive most speakers.



#### Ply 2.0

2x2.0 mm<sup>2</sup> sandwich design.  
Typical applications: Mid power up to short length high power Hi-Fi systems.  
Available in Ice Blue and White.



#### Ply 3.4

2x3.4 mm<sup>2</sup> sandwich design.  
Typical applications: High power Hi-Fi systems also up to intermediate lengths.  
Contact your local dealer for high power, longer cable lengths.  
Available in Ice Blue and White.

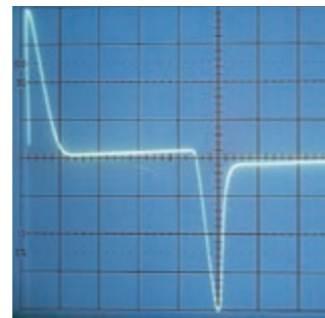

Fig. 1: Wide space cable losses

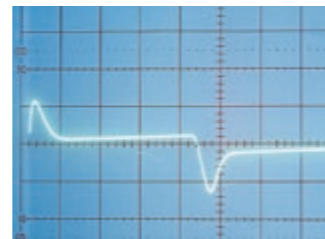

Fig. 2: Ply 2.0 losses

**Research References**  
Ben Duncan, 'Loudspeaker Cables', RP, Inst. of Acoustics, Nov '95. Also in Studio Sound & B'cast Eng. (all UK); & Stereophile (US) Dec '95. Also 'Modelling Cable', Electron-ics World, Feb '96, Measuring Spkr Cable Differences, Electronics World, June/July '96, & Black Box, Hi-Fi News & RR (all UK), June & July '96. Other Refs [1] M. Hawks-ford, Essex Echo, Hi-Fi News, Aug '85; Aug & Oct '86 & Feb '87. [2] F. E. Davis, Effects of Cable, J. AES, June, '91. [3] T. Ohasi, Nishina & Co, HF Sound >audio... affects brain, '91.

Item	Mechanical Specifications										Electr. Spec.	
	Cross. Area (mm <sup>2</sup> /AWG)	No. Cond.	No. Wires	Wire Dia. (mm)	Wire Material	Insulation	Ext. Size (mm)	Weight (g/m)	R (Ω/km)	L (μH/m)	R (Ω/km)	L (μH/m)
Ply 2.0	2.0 / 14	2	120	0.15	Tin Plated OFC	Heat & Ageing Resistant PVC	5.8x5.8	74	8.1	0.30		
Ply 3.4	3.4 / 12	2	192				7.2x7.2	97	5.1	0.20		
Ply 3.4 Wide	3.4 / 12		192				5x9	95	5.1	0.15		

Additional product information available in the final section

## Shielded Speaker Cables

SUPRA shielded cables radiate and pick-up less noise.

The result is immediately lowered noise floor and increased dynamics of the Hi-Fi system. Especially the so called μ-dynamics, the small details, suddenly stand out from a pitch black background, a truly remarkable discovery for most music lovers.

The modern multimedia system is a potential hotbed for noise pick-up and signal degradation and without attention, the most prestigious Hi-Fi system will not even come close to its peak performance. It is as simple as that.

Secondly, we must consider how magnetic fields, alternating electrical fields, electromagnetic (radio-) waves, etc affect us. Whenever possible, we at SUPRA think it is worthwhile to consider lowest possible levels of fields and radiations surrounding us.

#### Shielded SUPRA Ply 3.4/S

2x3.4 mm<sup>2</sup> sandwich design  
The shielded Ply 3.4/S provide low inductance and tin plating with a noise rejective shield which makes up for a one-of-a-kind speaker cable.

Typical applications: High power HiFi systems also up to intermediate lengths where maximum field rejection required.

Note below wiring instructions!

#### Shielded speaker cable wiring

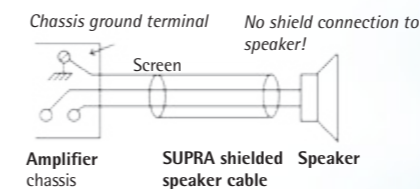

#### SUPRA Linc - May the force be without you

SUPRA Linc is an evolution of SUPRA Rondo and the already very low level of magnetic fields, have been supplemented with a shield blocking the electrical fields. Its properties enhance the transient transparency, similar to e.g. SUPRA Ply. Linc is short for Low Interaction Concept, is flexible and suitable for permanent in-wall installation.

#### Linc 2.5

2\*2.5 mm<sup>2</sup>  
Typical applications: Medium powered, short length high powered Hi-Fi system.

#### Linc 4.0

2\*4.0 mm<sup>2</sup>  
Typical applications: High powered, also longer lengths Hi-Fi.

Note!

The Linc speaker cables are directional. Refer to page 51 for further information.

Item	Mechanical Specifications										Electr. Spec.	
	Cross. Area (mm <sup>2</sup> /AWG)	No. Cond.	No. Wires	Wire Dia. (mm)	Wire Material	Insulation	Screen	Screen Coverage	Ext. Size (mm)	Weight (g/m)	R (Ω/km)	L (μH/m)
Ply 3.4/S	3.4 / 12	2	192	0.15	Tin Plated OFC	Heat & Ageing Resistant PVC	Braid 120x0,15	> 95%	7.3x7.3	156	5.1	0.20
Linc 2.5	2.5 / 13	+ Drain Wire	320	0.10			Aluminium/ PET Foil	100%	Ø8.1	94	6.8	0.42
Linc 4.0	4.0 / 11		511	0.10					Ø8.7	135	4.9	0.44

Additional product information available in the final section

Ply  
Speaker Cable

PLY

LINC

## Pre-terminated PLY Cables



Supplied with banana/BFA or spade/fork connectors

### Ply 2x2.0 och Ply 2x3.4 CombiCon Crimp

2x2.0 mm<sup>2</sup> or 2x3.4mm<sup>2</sup> sandwich design.

Ply combines low induction and tin plating which provides for explosive dynamics. Ply is a multi-award winner and one-of-a-kind quality cable from SUPRA. Pre-terminated with CombiCon connectors providing a 6mm threaded body. Choose between banana/BFA or spade/fork connectors.

### Crimping?

Crimping means pressing together under very high pressure. A properly crimped joint brings the materials together in an airtight, homogeneous and electrically "invisible" joint that is superior in this application.



All factory crimping is performed using dedicated machine tools. The picture illustrates the process using a hand crimping tool.

## Shielded SUPRA PLY

Ply combine low inductance and tin plating which provides for explosive dynamics.

### Ply 2x3.4/S CombiCon Crimp

2x3.4 mm<sup>2</sup> sandwich design.  
Pre-terminated with CombiCon connectors providing a 6mm threaded body. Supplied with banana/BFA or spade/fork connectors.

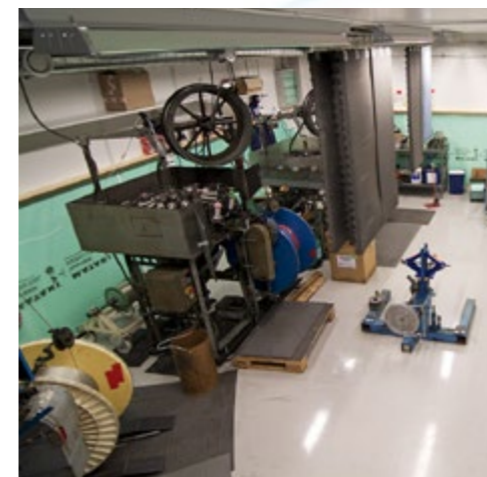
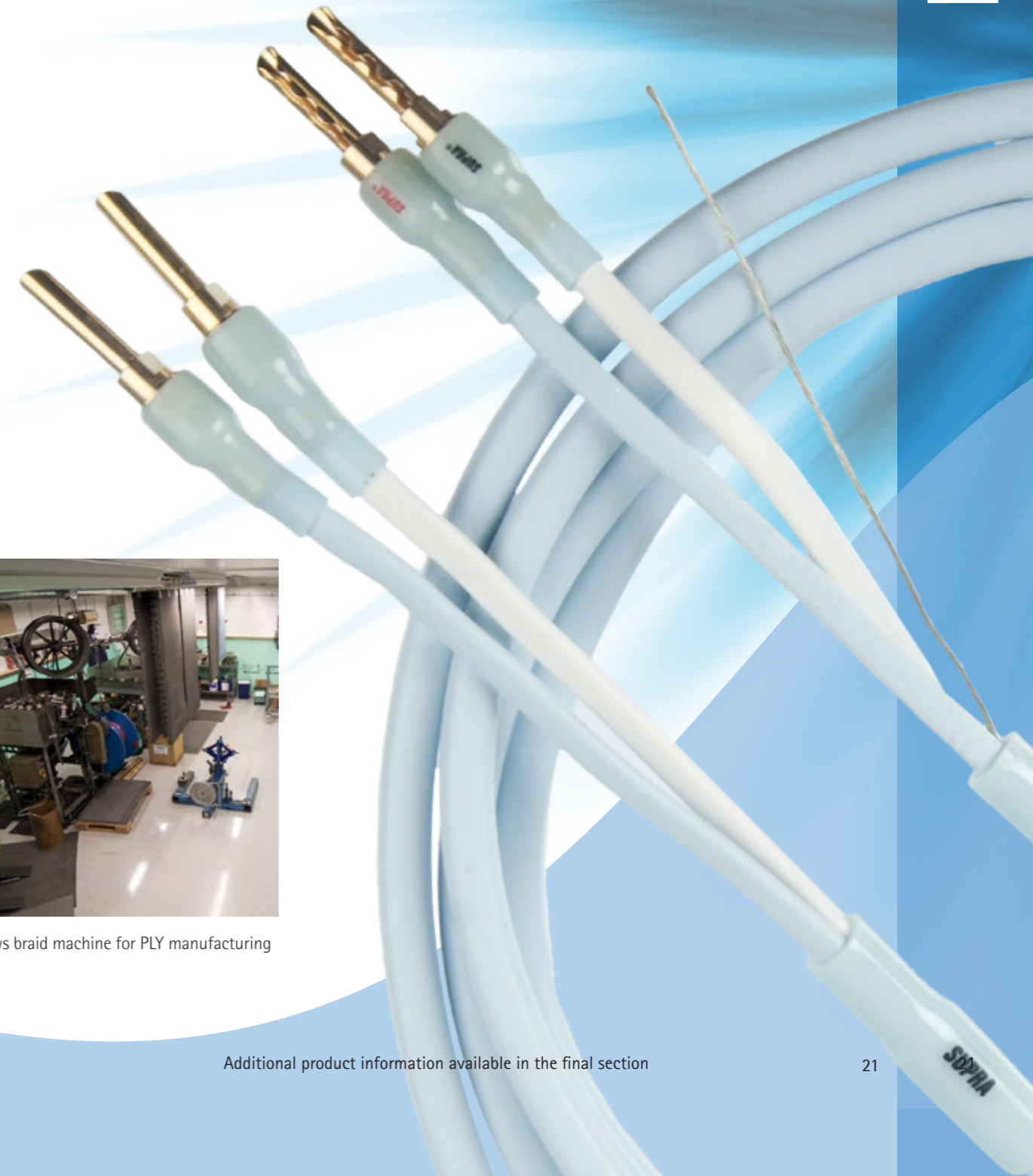

Picture shows braid machine for PLY manufacturing



## Rondo Series- On stage!

SUPRA Rondo is a series of versatile, highly flexible round speaker cables, with short pitch wound conductors. The all-round properties make this cable suitable for a wide range of applications. Thanks to the short pitch of the conductors, the cable inductance is kept low hence reducing magnetic fields and providing fast musical response. The production method allowed us to twin with short pitch and still keep it resistant to handling fatigue, making it especially useful on-stage. The strands are tin plated for corrosion resistance and benign musical behavior. It is especially suitable for bi-wired and bi-amplified speakers, thanks to the four leads in square.



### Rondo 4x1.6/H

4x1.6mm<sup>2</sup>

Typical applications: Mid powered, short length high-powered and/or in bi-wired or bi-amplified Hi-Fi system. Protected by flame retardant insulation ECCOH.



### Rondo 2x2.5

2x2.5mm<sup>2</sup>

Typical applications: Hi-Fi or on-stage.



### Rondo 4x2.5

4x2.5mm<sup>2</sup>

Typical applications: High powered, short to intermediate lengths and/or in bi-wired or bi-amplified Hi-Fi system or on-stage.



### Rondo 4x4.0

4x4.0mm<sup>2</sup>

Typical applications: High powered, also longer lengths and/or in bi-wired or bi-amplified Hi-Fi system or on-stage.



Tip!

Four conductor Rondo provides for very low inductance by following wiring example in the figure, i.e. 0.25-0.35µH respectively. This configuration is called Star Quad.

Note!

The Rondo speaker cables are directional. Refer to page 51 for further information.

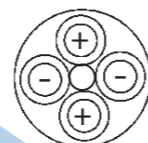

Item	Mechanical Specifications								Electr. Spec.		
	Cross. Area (mm <sup>2</sup> /AWG)	No. Cond.	No. Wires	Wire Dia. (mm)	Wire Material	Insulation	Flame Retardant & Halogen Free	Ext. Size (mm)	Weight (g/m)	R (Ω/km)	L (µH/m)
Rondo 4x1.6/H	1.6 / 15	4	90	0,15	Tin-Plated OFC	PE FRHF	Yes, see p45	Ø8.5	111	10.8	0.32
Rondo 2x2.5	2.5 / 13	2	320	0.10	Tin-Plated OFC	Heat & Ageing Res. PVC	No	Ø7.7	110	6.8	0.40
Rondo 4x2.5		4						Ø9.7	170		0.35
Rondo 4x4.0	4.0 / 11							Ø11	236	4.3	0.40

Additional product information available in the final section

# SUPRA / S w o r d

## SUPRA Sword - The High End

Regardless of the price we are proud to say, humbly, this is one of the best speaker cables there is. Completely transparent, perhaps a worn-out cliché, is still what most users and tests agree on. The secret? The bifilar-wound litz conductors comprising 24 individually insulated strands per pole, 12 wound in one direction, the remaining 12 in the opposite, resulting in magnetic field cancellation and very low inductance. Further to the litz wound and individual insulated strands, dynamic skin-effect is cancelled. The Sword behaves as a non-inductive and in-phase cable. The only thing not cancelled is the sound, allowing you to hear every little note of the music.

### How does it sound?

The best way to describe is *nothing*, but that is hard to imagine, so we will try to explain. SUPRA will maintain the true signal put out from your Hi-Fi system giving a completely transparent transition from amplifier to speaker. You will hear the music, nothing more, nothing less.



SUPRA Sword - The High End Series  
SUPRA offer a range of analogue cables in the Sword segment, allowing you to optimize your entire Hi-Fi system. Refer to page 41 for information.



Item	Mechanical Specifications							Electrical Specifications				
	Cross. Area (mm <sup>2</sup> /AWG)	No. Cond.	No. Wires	Wire Dia. (mm)	Wire Material	Insulation	Jacket	Ext. Size (mm)	R (Ω/km)	L (µH/m)	Phase Disloc. (0.5-100kHz)	Phase Error
Sword	3.0 / 12	2	12 + 12	0.4	Enameled OFC	PE	PVC	9.3x18.4	5,2	0.25	0.96 Deg.	0

Additional product information available in the final section



## We only sell Sword pre-terminated!

The reason is that the transition between the cable and connectors is very critical. In order to maintain the superior cable and contact properties, we reached the conclusion to keep this in-house. We crimp the unit together at high pressure, making a perfect, air tight, joint. It is supplied in an exclusive Mahogany Box comprising both banana and spade connectors.

We simply could not resist an extra treat for this remarkable cable.



### Sword Jumper, 28 cm

Permanent fork terminals, i.e. not replaceable CombiCons. Suitable to replace the original, often sub-standard, metal sheet jumpers supplied with the speakers. In most cases, a dramatic speaker performance boost!



The standard jumper supplied with most speakers, is a very good example how to make a highly inductive conductors. They are the reason for the development of our Sword Jumpers.

# SUPRA Quadrax



Affordable High-End  
High Definition

Standard



Bi-Amp

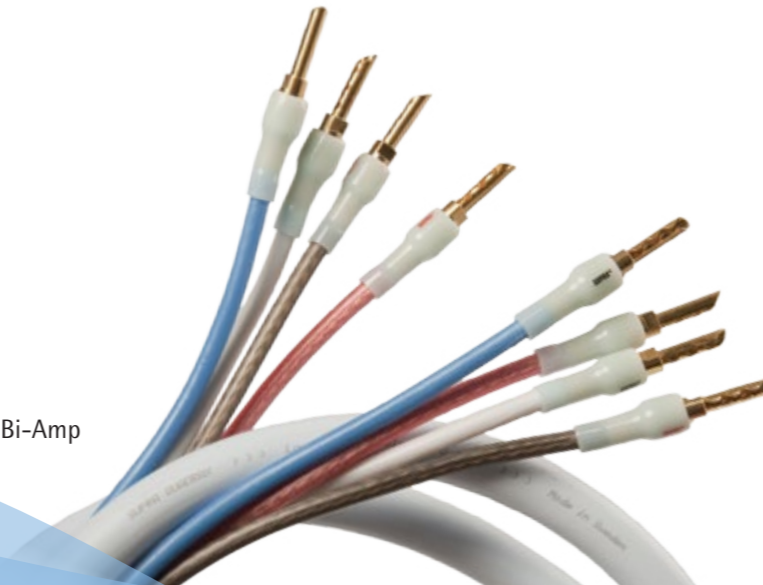

Bi-Wire

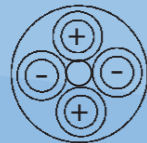

## SUPRA Quadrax Speaker Cable □ Built-in Star Quad configuration

It is all new and it has all necessary characteristics of becoming a future-classic SUPRA Cable. It is a fusion of techniques that perhaps is best described as four Star Quad-configured, one-layer-spun on insulating core, multi-strand conductors, leaving the inductance, noise pick-up and signal degradation so low, it has never before been available at this price level!

By spinning a multi-strand layer on an insulating core, we increased the comparative conductor cross section, leading to an inductance as low as 0.3mH/m, one of our hallmarks. The result is dynamic, transient rich and transparent. We also optimized the strand spinning direction of each conductor to further enhance the low inductance, timing and interference immunity.

Finally, this cable also offers low capacitance, a very rare combination of characteristics. Thanks to its cable geometry and high grade polypropylene insulation, the high frequency drop-off is negligible minimizing the need of any frequency compensation.

This is a cable we are truly proud of and one we feel will be a worthy contestant in any Hi-Fi system. Or Hi-Fi test.



Banana and fork terminals are included in all Quadrax cables.

## Quadrax 2x4.0 Standard CombiCon Crimp

Single-wire 2 + 2 conductors

## Quadrax 4x2.0 Bi-amp CombiCon Crimp

4 + 4 conductors

## Quadrax 4x2.0 Bi-Wire CombiCon Crimp

2 + 4 conductors

Factory terminated, because the transition between the cable and connectors is very critical. In order to maintain the superior cable and contact properties, we reached the conclusion to keep this in-house. We crimp the unit together at high pressure, making a perfect, airtight joint.



Item	Mechanical Specifications								Elec. Spec.	
	Cross. Area (mm <sup>2</sup> /AWG)	No. Cond.	No. Wires	Wire Dia. (mm)	Wire Material	Insulation	Jacket	Ext. Size (mm)	R (Ω/km)	L (μH/m)
Quadrax	2.0 / 14	4	120	0.15	Tin Pl. OFC	PP	PVC	Ø15	8.1	0.28

Additional product information available in the final section

Additional product information available in the final section

**Boxcon**

24K gold plated speaker chassis contact for cable areas up to 10mm<sup>2</sup>, fork or banana.

Suitable for speaker cabinet walls up to 29mm thickness and 8mm hole.

Available in both red and black to distinguish polarity.

1 pair (red/black)/pack. Available also in bulk = 50 pairs



**Fork**

24K gold plated fork for speaker terminals or heavy binding posts. Versatile, allows straight or 90° turned connection, cable cross sections up to 10mm<sup>2</sup>, and additional banana in- or out-bound connection with the supplied adapter screw. Fork width 5.5mm. Our most copied product world wide.

2 pair/pack. Available also in bulk = 50 pairs



**Fork XL**

Similar to standard Fork, except with a wider spacing of 6.5mm and banana adapter screw offered separately.

2 pair/pack. Available also in bulk = 50 pairs



**Banana**

24K gold plated 4mm banana plug for speaker terminals or heavy binding posts. Versatile, allows straight or 90° turned connection, cable area up to 10mm<sup>2</sup> and with a black or red plastic cover to distinguish polarity. Also fits BFA banana binding posts.

2 pair (2 red + 2 black)/pack. Available also in bulk = 50 pairs



**CombiCon Banana/BFAM6**

24K gold plated speaker connector for cables up to 6mm<sup>2</sup>. Allows straight or 90° cable connection. A supplementary fork is possible to connect, or if the cable is connected at 90°, a straight connected banana. The banana tube is made from gold plated beryllium-copper, which is a strong and conductive alloy.

2 pair/pack. Available also in bulk = 50 pair banana and 50 pair connector body



**CombiCon Spade M6**

24K gold plated speaker connector for cables up to 6mm<sup>2</sup>. Allows straight or 90° cable connection. The specially designed fork allows for binding posts between 4.5mm up to 9mm. A supplementary fork is possible to connect, or if the cable is connected at 90°, a straight connected banana. The spade is made from solid copper and gold plated.

2 pair/pack. Available also in bulk = 50 pair banana and 50 pair connector body



**CombiCon Kit**

The kit consists of four pieces of Banana/BFA M6, four Spade M6 and two pair connector body.

**CombiCon Assortment Box**

Assortment for dealers, content:  
50 pair banana/BFA  
50 pair Spade (Fork)  
50 pair Connector Body  
Wooden Box included



**Speaker Connectors**

**Supra CombiCon Crimp Assortment**

(for SUPRA dealers)

CombiCon crimp connectors for loudspeaker cables, with M6 threaded body allowing either a corresponding banana (BFA) or a fork. The body is crimped on the cable, using the supplied crimping tool. Crimping is the best connection, since the result is an air tight and uniform connection, almost as solid. The body is covered by a rubber sleeve. The body is available in four sizes, covering cable cross sections from 0.75mm<sup>2</sup> up to 6mm<sup>2</sup> and they are manufactured from solid copper and gold plated.



The Assortment - Supplied in a convenient aluminium box with tool.

- 50 pcs Banana/BFA tips
- 50 pcs Fork (spade) tips
- 50 pcs Connector body 1 for cable cross section 0.5mm<sup>2</sup> to 1.6mm<sup>2</sup>
- 50 pcs Connector body 2 for cable cross section 1.7mm<sup>2</sup> to 2.5mm<sup>2</sup>
- 50 pcs Connector body 4 for cable cross section 2.6mm<sup>2</sup> to 4.0mm<sup>2</sup>
- 50 pcs Connector body 6 for cable cross section 4.1mm<sup>2</sup> to 6.0mm<sup>2</sup>
- 50 pcs Rubber sleeves for body size 1-2 colour black
- 50 pcs Rubber sleeves for body size 1-2 colour red
- 50 pcs Rubber sleeves for body size 4-6 colour black
- 50 pcs Rubber sleeves for body size 4-6 colour red
- 50 pcs CombiCon outer body, Black
- 50 pcs CombiCon outer body, Red
- 1 pc Crimping Tool



**CombiCon**

The SUPRA CombiCon product line consists of two parts, the Connector Body and the Connector.

**The Connector Body**

The cable connects two ways, straight or 90°. It is printed in black or red to distinguish correct polarity.

**The Connector**

The Connector is available in a Banana/BFA and a Spade. The spade is slightly angled to connect also to tight and difficult binding posts. Its clever design provides also for a wide range of binding post dimensions, refer to the drawing below. The picture to the right illustrates the CombiCon wiring options.

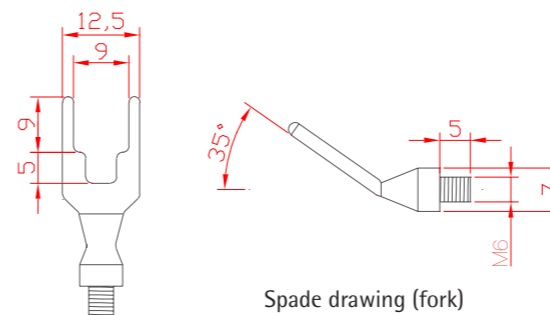

SPEAKER CONNECTORS

# OPTICAL DIGITAL ANALOGUE

*To be able to successfully connect all units in a Hi-Fi and Home Cinema System, interconnects are required. This might appear easy, but in reality it is not. You may encounter geographic standards, brand standards and even wide spread standards that do not specify all necessary characteristics and leave room for interpretations.*

*The video field alone contains countless interfaces especially now when video will play from so many different types of hardware; computers, gaming consoles, media players, DTV/satellite receivers, among others.*

*Consequently SUPRA has developed a wide range of interconnects and we continuously monitor and evaluate new connector types on the market and as soon as new interfaces become more or less "standard" we will quickly include them in our world wide product lines.*

*In line with the SUPRA No-Nonsense Design concept there is one characteristic which is particularly important to emphasise: low capacitance. The capacitance can be illustrated by the garden hose jet. The lower the hose internal volume is (+), the better the hose routing is (+) and the stiffer the hose walls is (+), the quicker the jet reacts (=) when adjusting the tap.*

*Any capacitance, on the other hand, "absorbs" every attempt to increase the jet by increasing the water pressure and therefore consequently will delay and suppress the jet spray. When a low level interconnect acts ideally, the output signal rises exactly in the same moment and to exactly the same level as the input signal. Supra always pro-actively select the materials and design to suppress and when possible cancel) the unwanted capacitive electrical behaviour.*

## ZAC Fibre Optic Interconnect

ZAC is the abbreviation for Zero Attenuation Concept which means that nowhere in the cable will the light encounter any obstacles distorting or suppressing the signal. This means that the cable can carry the optical signal over longer distances without degradation.

When manufacturing optical interconnects, the quality of the fibre and tip polishing is the most important issue. We use a Japanese plastic fibre providing strength and flexibility, but require also a very thorough polishing process with an innovative fibre tip curving cancelling divergence losses.

The features & benefits are:

- Bandwidth - Allows high definition music signal
- Interference immune - Will not pick-up any noise
- Non-radiating - Will not radiate any noise
- Non-conductive - Will not create ground loop noise
- Low weight - Will not act as lever on the connectors
- Flexible - Easy to route the cable, more flexible than glass
- Long lengths - Provides for long distance signal transmission without loss.

## ZAC Toslink ■

**Toslink to TosLink**  
More flexible than glass fibre.  
Top seller cable available up to 20 meters.  
Suitable for most Hi-Fi systems.

## ZAC MinTos ■

**Mini plug to TosLink**  
Same fibre except for a 3.5mm mini plug at one end.  
Suitable design for hardware such as computers, Airport Express, external D/A-converters and amplifiers with digital in- and outputs.

## ZAC Mini ■

**Mini plug to mini plug**  
Same fibre and here provided with two 3.5mm mini plugs. Suitable between some computers and MP3 players.



ZAC Mini

ZAC Toslink

ZAC MinTos

Additional product information available in the final section

## Digital cables

AES EBU 110ohm / Coaxial 75ohm

### DAC

Digital cable @110ohm, suitable in some high end applications and for professional use such as studios and on stage.

Our fastest cable, transfer high definition music or program content at 24bits@192KHz and over.

Terminated with is e.g. SUPRA Swift XLR.



### DAC

The cable provides for extremely low capacitance in order to react very fast. The DAC cable is insulated with a foam PE plastic reducing the plastic content and resulting in air insulation, today the most efficient electrical insulation.

Further the foam plastic is a) softer hence flexible, b) lower weight, and c) lower mass absorbing hence delaying the signal. We have achieved 0.45µF/m, which is considered very low and consequently will not delay or dampen to any significance in normal intended use.

The result is far better to some competitive materials like e.g. Teflon. The shield will protect the signal from pick-up of noise. When the signal transmission is flawless, the receiving circuitry need not correct any errors or misinterpretations, you will be listening to the music rather than Hi-Fi system.

### Trico

Video/digital cable @ true 75ohm. Dual screen, fast and very low dampening, only 0.6dB/100m allowing long distance signal transmission.

Suitable contacts are e.g. SUPRA PPX, MP-8 and BNC-8.



### Trico

This cable offers very low, only 0.58µF/m, capacitance providing fast transmissions and low damping. The shield is highly efficient and is made of a) an inner braid of silver plated OFC copper and b) an outer of OFC copper. The core lead is made of silver plated OFC copper. The silver plating is particularly efficient for high frequency conductivity; here we in fact utilize the skin-effect. Trico's high-tech damping characteristics are usually found in a much higher price segment; 0.6dB/100m@1MHz and 7.1dB/100m@100MHz, i.e. true 75ohm and its impedance is also exceptionally stable ±1.5ohm@f≤100MHz. Behind all this high-tech vocabulary, the Trico cable characteristics enables high end performance in your Hi-Fi system, allowing your media player, CD transport or similar to transmit high definition program content to your D/A converter or amplifier so you can listen to the music instead!



SUPRA GS, Ground Separators

## Aerial Cable

Coaxial digital 75ohm

### AnCo

Aerial/digital/video cable 75ohm

SUPRA AnCo is designed for all 75ohm applications such as digital audio (S/PDIF), analogue radio and TV broadcasts and composite video. Both the solid core lead and the screen are silver plated for response at high frequencies. Foam PE insulation provides low capacitance and high speed.

Updated in 2008 with dual screen, it has become a high performer in the aerial market.



### AnCo-TV Aerial Cable 75ohm

To get top notch performance from your TV, the aerial signal must be strong. Thanks to silver plating, dual screens, PE insulation and SUPRA ACON gold plated RF tight aerial connectors, we guarantee maximum aerial signal to your TV, provided that aerial, broadcast content and so forth is of sufficient quality.



### GSS GSB FCON

SUPRA GS, Ground Separator, for aerial systems. This may well be the single most important trouble shooter. When a multitude of electrical devices must co-exist, it is predetermined that you eventually get a ground loop, meaning you cannot connect e.g. your TV, to your A/V Receiver without getting a background hum.

Available in straight or bent versions.

## Digital Cables

Koaxial 75ohm / AES EBU 110ohm

### Digital formats

The cable choice is a delicate procedure in all electrical digital applications.

The technical term used is characteristic impedance, i.e. how the transmitter, receiver and cable match. Mismatch may cause jitter (common factor for timing problems) or even loss of signal.

- S/PDIF = Sony/Philips Digital Interface.
- AES/EBU = Audio Engineering Society and European Broadcasting Union.

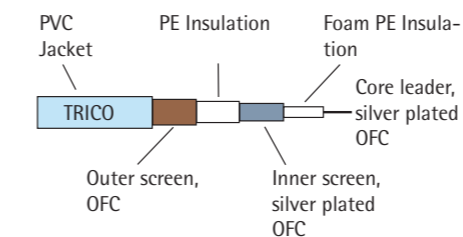

Trico-RCA 75ohm S/PDIF Trico-RCA/BNC Trico-RCA/MP DAC-XLR 110ohm AES/EBU

Item	Mechanical Specifications											Electr. Spec.			
	Application Examples	Cross. Area (mm <sup>2</sup> /AWG)	No. Wires	Wire Dia. (mm)	Wire Material	Insulation	Inner Screen Coverage	In. Screen Insulation	Outer Screen Coverage	Jacket	Dia. (mm)	Weight (g/m)	C	Imp. Z (Ω)	Velo. Factor
DAC	Analog./Digital	0.54 / 20	19	0.19	OFC	PE Foam	Cond. Nylon, 100%	-	-	Heat & Ageing	Ø6.1	43	45	110	0.78c
Trico	Video/Digital	0.71 / 19	7	0.36	Silver	PE Foam	Braid Ag OFC, >95%	PE	Braid OFC, >90%		Ø8.2	105	58	75	0.78c
AnCo	Video/Aerial	0.28 / 23	1	0.6	Plat. OFC	PE	Aluminium Foil	-	Braid Sn OFC, >95%	Resistant PVC	Ø6.2	52	72	75	0.72c

Additional product information available in the final section

Additional product information available in the final section



We are convinced that Cat7+ is one of the best network cables there is!

## SUPRA Cat7+ FRHF Network Cable

SUPRA Cat7+ Digital Data Cable ■

There are two areas in a data network cable that must be perfectly designed, a) the shielding, and b) the twinning of the two lead pair. The reason is cross-talk, when the signal "jumps" to the adjacent pair of leads.

One important difference from digital audio circuitry is that network transmission follows a protocol with handshake, a confirmation between sender and receiver. If the cable cannot maintain signal integrity, transmission speed will drop until transmission is accomplished, in worst case leading to signal drop-outs.

SUPRA Cat7+ surpasses the specification category 7A according to EN 50288 and IEC 61156. The cable shows excellent NEXT, low damping, good shielding (every pair separately and finally all together, so called SSTP), low SKEW, bandwidth @1300MHz.

The solid 22AWG copper leads, foamed PE plastic, efficient shielding make extremely long distance installation possible, thanks to the low capacitance.

Typical applications: Installation cable for network. Ideal for all class D up to FA Multimedia applications, i.e. video, data, voice >10 GbE according to IEEE802.3an, VoIP, PoE.

### FRHF

The abbreviation is short for Flame Retardant Halogen Free, meaning that the cable is fire retardant and approved for use and installation in public areas and buildings. The specific characteristics of this classification are:

- Excellent flame retardancy
- Halogen free
- Less smoke in case of fire (Lo-smoke)
- Less hazardous gas emission



### SUPRA RJ45

Specially developed network cable connector for AWG22 strands.

Item	Mechanical Specifications										Electrical Specifications					
	Application Examples	Cable	Cross. Area (mm <sup>2</sup> /AWG)	Wire Material	Insulation	Inner Screen Coverage	Jacket	Ext. Size (mm)	Weight (g/m)	R (Ω/km)	C (pF/m)	Bandwidth @100MHz (MHz)	Skew ns/100m	Imp. Z (Ω)	Velo. Factor	
Cat 7+	Ethernet >10Gb	4 pair, Cat7A S/STP	0,26 / 23	Solid OFC	PE Foam	Alu. Band & Braid,100%	PE FRHF	Ø8	67	57.1	40	1300 MHz	5 ns/100m	100	0.8c	

Attenuation: 1MHz/1.7 dB, 10MHz/4.5dB, 100MHz/15.4dB, 600MHz/40.4dB, 1300MHz/61.4dB

Additional product information available in the final section



## SUPRA USB 2.0

SUPRA USB 2.0 – Digital Data Cable ■



The sales of USB devices has increased exponentially and we are proud to offer our new cable for: digital audio convertors, music streaming from computers, multimedia players, among other devices providing a USB interface. There is a great need for better cables since the failed bit transmissions will undoubtedly be detected when listening to your music, since the error correction and number of re-tries will leave audible traces.

Many USB interface users are accustomed to quite short cables, but not anymore. SUPRA USB 2.0 allows for a distance of 15metres between your devices!

The trick is, as always, shielding, separate for each pair of leads correctly twinned and an exact impedance matching of 90ohm, which is vital for these applications. SUPRA USB 2.0 will reward you with a dynamic, rich and detailed music experience. Undoubtedly!

### Features Et Benefits

- Long cables lengths - provides for long distances between devices
- Correct data transfer - utmost sound capabilities
- Perfect shielding and twinning - minimum signal degradation
- Robust type A and type B connectors - reliable, long mobile life
- Made in Sweden - Modern research, production and quality

Item	Mechanical Specifications										Electrical Specifications					
	No. of Pairs	Cross. Area (mm <sup>2</sup> /AWG)	No. Wires	Wire Dia. (mm)	Wire Material	Insulation	Screen	Jacket	Ext. Size (mm)	Weight (g/m)	R (Ω/km)	C (pF/m)	Imp. Z (Ω)	Velo. Factor		
USB 2.0	2	0.24 / 23	19	0,127	Tin Plat. OFC	PE	Alu/Pet Foil	PVC	Ø7.5	56	72	52	90	0.66c		

Additional product information available in the final section

When only the best is good enough!

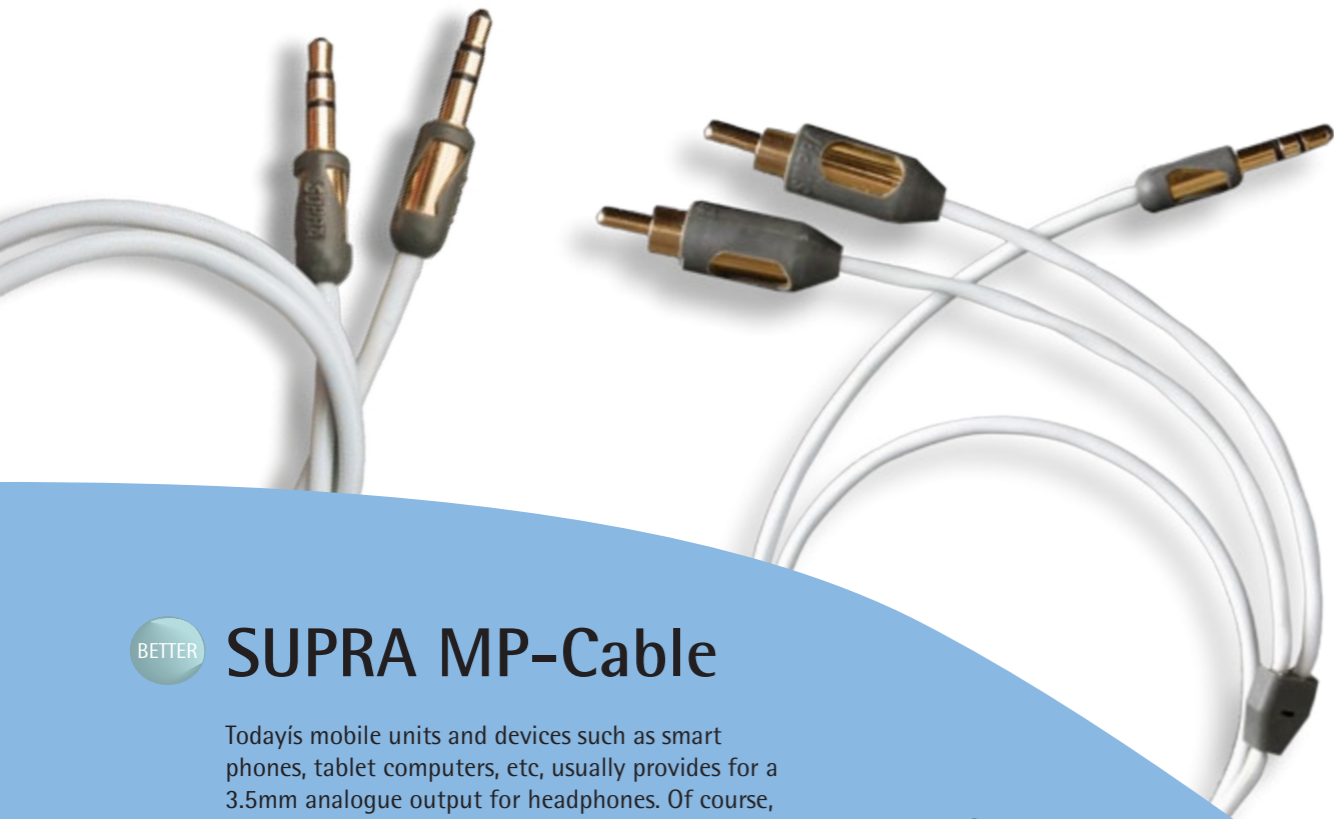

BETTER

## SUPRA MP-Cable

Today's mobile units and devices such as smart phones, tablet computers, etc, usually provides for a 3.5mm analogue output for headphones. Of course, it is also possible to connect these devices to other audio devices. It is increasingly popular with a Hi-Fi-system of just a pair of active stereo speakers, a head-phone set and on-line music providers in addition to a local music library on a NAS server. We have developed two cables covering most mobile applications. The flexible dimension and sturdy, moulded, gold plated connectors, make them ideal for mobile use.

### MP-2RCA

3.5mm stereo mini plug to a pair of phono/RCA plugs.

Gold plated and fully shielded make them ideal for connecting your mobile device to your analogue Hi-Fi system or directly to your active speaker set-up.

### MP-MP

3.5mm stereo mini plug to a 3.5mm stereo mini plug

Gold plated and fully shielded make them ideal for connecting your mobile device to your portable speaker, computer speakers or in-car stereo.

Additional product information available in the final section

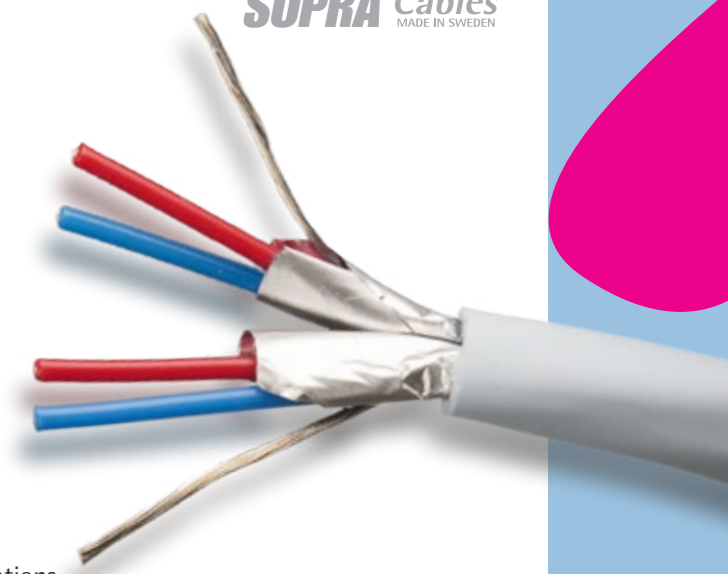

BEST

## SUPRA BiLine

### BiLine MkII

Analogue low level interconnect for stereo applications. Improved MkII version. Round interconnect cable with two pairs of twisted, separately shielded leads, providing cable characteristics such as low capacitance and good noise suppression, making it suitable over longer distances before audible impact. For balanced or semi-balanced connections. Aluminium screen.

Typical applications:

- Analogue interconnects e.g. between pre- and power amplifier.
- Y-connection e.g. A/V receiver to subwoofer with two inputs and smartphone, computer, iPad to stereo amplifier input.

Suitable connectors: RCA-6, MP-8, Swift XLR and PPX, refer to page 48-49 for additional information.

BEST

## SUPRA BiLine-MP

Mp3, iPod, smart phone or computer cable

Offers the best possible sound quality from your mobile device to your stereo set, providing fully shielded, low noise music transmission for your maximum pleasure. Equipped with our proprietary connectors MP-8 and RCA-6.



Item	Mechanical Specifications										Electrical Specifications			
	No. of Pairs	Cross. Area (mm <sup>2</sup> /AWG)	No. Wires	Wire dia. (mm)	Wire Material	Insulation	Screen	Jacket	Ext. Size (mm)	Weight (g/m)	R (Ω/km)	C (pF/m)	Imp. Z (Ω)	Velo. Factor
Biline	2	0.24 / 23	19	0,127	Sn plat. OFC	PE	Alu/Pet Foil	PVC	Ø7.5	56	72	52	90	0.66c

Additional product information available in the final section

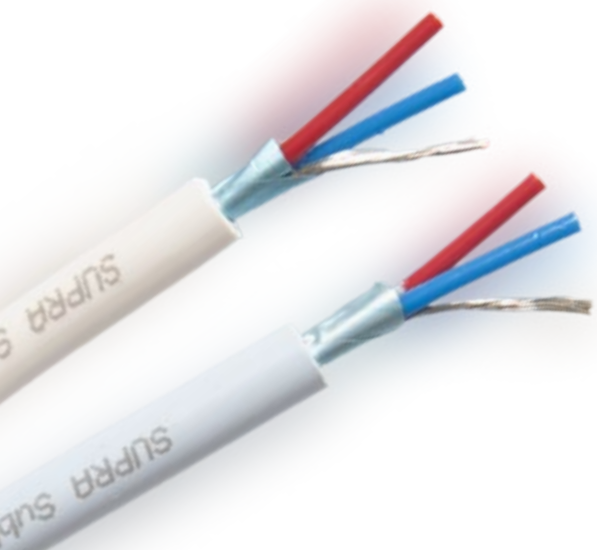

## SUPRA SubLink ■ □

Subwoofer / Analogue Hi-Fi

Interconnect cable comprising two conductors and a screen for efficient shielding suitable for balanced or semi-balanced connections. Low capacitance and efficient noise rejection, provides for long distance routing for e.g. subwoofers. Available in SUPRA Ice Blue or White. Suitable connectors are RCA-6 and Swift XLR.



SubLink-RCA

### SubLink-RCA

Mono subwoofer interconnect between e.g. A/V receiver and subwoofer, so called LFE connection. Low capacitance and efficient noise rejection provide for long distance routing. Pre-terminated with RCA-6 connectors.



Sublink RCA-XLR

### Sublink RCA to XLR/m

Mono semi-balanced interconnect between e.g. pre-amplifier and an active speaker, or pre-amplifier and a mono-block with a RCA output and XLR input. Low capacitance and efficient noise rejection provide for long distance routing common for these applications. Pre-terminated with RCA-6 and SWIFT XLR male connectors.



Y-Link

### Y-Link

Stereo input subwoofer interconnect between e.g. A/V receiver and subwoofer offering a stereo input instead of a single LFE (common among dedicated Hi-Fi subwoofers). Low capacitance and efficient noise rejection provide for long distance routing. Pre-terminated with PPX and RCA-6 connectors.



Sublink XLR-XLR

### Sublink XLR/f to XLR/m

Mono balanced interconnect between e.g. pre-amplifier and an active speaker, or pre-amplifier and a mono-block with a RCA output and XLR input. Low capacitance and efficient noise rejection provide for long distance routing common for these applications. Pre-terminated with SWIFT XLR connectors.

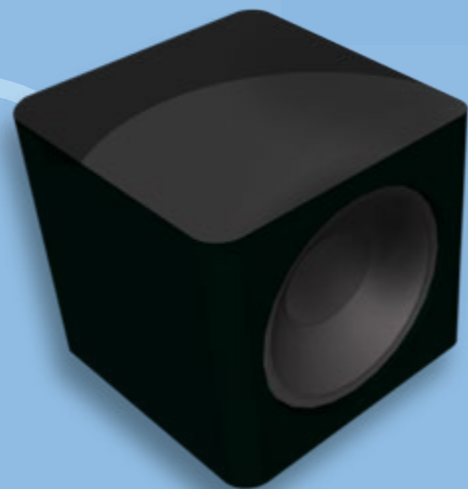

## Why SUPRA?

There are many cable manufacturers today and how to determine which cable is the best? We at SUPRA know how difficult this is. We too choose various products, car, household machinery and so forth so we know how deceptive outer appearance may be.

You may have already noted the SUPRA cables quite distinctive exterior, SUPRA Ice Blue. This is a conscious choice, offering a distinctive brand image, very typical Scandinavian Swedish and guides your awareness from the clean, sensible appearance to the

astonishing performance that awaits beneath.

We wish that our customers enjoy a sensational feeling that comes from knowing the true nature of performance under the surface, with a resemblance of the clean and calm Nordic water and ice.

We guarantee our cable performance to meet and exceed the requirement for transmission without signal degradation within the limitations we specify. Always!

We continue to be in the forefront, thanks to domestic R&D, advanced testing and production. Our cables meet the toughest requirements from the latest standards and regulations and we even push the envelope with our creative innovations. Our custom-designed production plant and thorough testing, ensures top notch products today and tomorrow from Ljungskile, Sweden.

**SUPRA**  
Unbeatable  
price/performance  
ratio!

Item	Mechanical Specifications										Electrical Spec.			
	No. of Pairs	Application Examples	Cross. Area (mm <sup>2</sup> /AWG)	No. Wires	Wiredia. (mm)	Wire Material	Insulation	Screen	Jacket	Ext. Size (mm)	Weight (g/m)	R (Ω/km)	C (pF/m)	Velo. Factor
Biline	2	Stereo Subw., mp3	0.24 / 23	19	0,127	Tin Plat.	PE	Alu/Pet Foil	PVC	Ø7.5	56	72	52	0.66c
SubLink	1	Mono Subwoofer				OFC				Ø6.0	48	72	52	0.66c

Additional product information available in the final section

# Analogue Hi-Fi Interconnect Cable

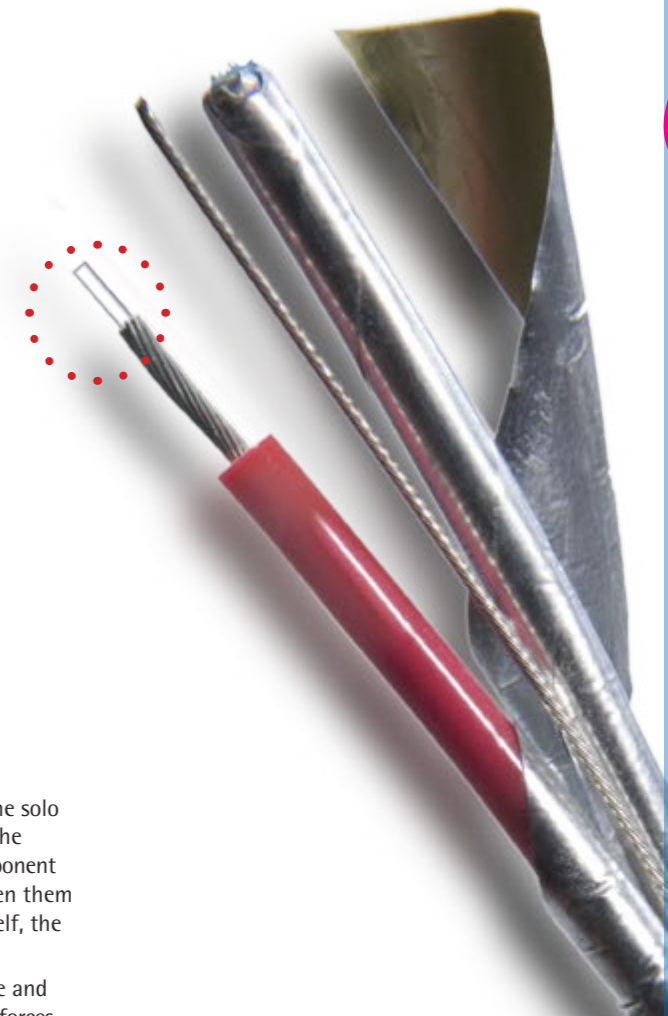

## DAC

Hi-Fi 

An interconnect should provide for lowest possible capacitance. The reason is not to influence the timing in any way, the signal from the cable should be completely in-sync with the input irrespective of frequency. The result will be good dynamics, fast clean transients and the sound stage will stay intact, due to the correctly replayed original signal. DAC insulation is foamed PE (poly-ethylene) and it is shielded with the strong semi-conductive twisted nylon ribbon. Its conductive speed reaches 78% of the speed of light, while commonly used Teflon only reaches 71%.

Typical applications: Analogue interconnect between e.g. CD/pre-amplifier/power amplifier.

Suitable connectors: PPX, PPSL, RCA-6 and Swift XLR

## Dual

Hi-Fi 

Interconnect with dual-in-line configuration for balanced or semi-balanced wiring. Aluminium foil ribbon and optimal capacitive performance provides for a competitive entry-level interconnect.

Typical applications: Analogue interconnect between e.g. CD/pre-amplifier/power amplifier.

Suitable connectors: RCA-6 and Swift XLR

### Semi-balanced connection with RCA

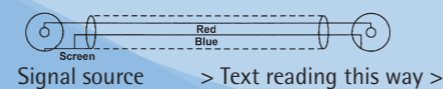

### Balanced connection with XLR

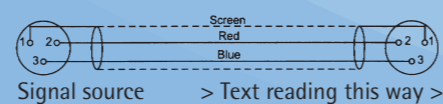

## SUPRA EFF-I

Analogue Hi-Fi cable  Multi-test winner!

To reproduce the most exquisite details in music e.g. the solo violinist or perhaps even recognize which Stradivarius he plays, must be the goal for every Hi-Fi system. Each component must be a perfect match and the interconnects between them providing no audible impact from the interconnect itself, the surroundings or any impedance mis-match.

An excellent cable must provide for lowest capacitance and skin-effect. The latter affects the dynamics noticeably; it forces the higher frequencies out to the surface of the conductors. As frequencies change so does conductivity. Sound stage and frequency response will deteriorate and musical vitality is lost. To minimize the skin-effect, EFF-I is designed according to Equalized Frequency Flow Technique. By twinning the strands on a insulator core, a tube-like conductor is achieved with 0.2mm wall thickness with enough allowance for audible skin-effects. The result is equal transmission for all frequencies and the music signal that SUPRA EFF-I carries is true to the source.

### Effective skin depth

$$\delta = 1/\sqrt{\pi \mu_r \mu_0 \sigma f}$$

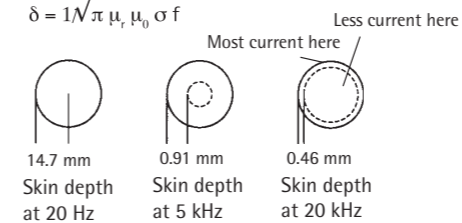

## EFF-I

Hi-Fi 

Analogue interconnect, e.g. CD/pre-amplifier/power amplifier

Suitable connectors: SUPRA PPSL, PPX, PPR and SWIFT XLR

Item	Mechanical Specifications								Electrical Spec.				
	No. of Pairs	Cross. Area (mm <sup>2</sup> /AWG)	No. Wires	Wire Dia. (mm)	Wire Material	Insulation	Screen	Jacket	Ext. Size (mm)	Weight (g/m)	R (Ω/km)	C (pF/m)	Velo. Factor
Dual	2	0.24 / 23	19	0.127	Tin Pl. OFC	PE	Alu/Pet Foil	Heat & Ageing	2 x Ø5.5	70	72	52	0.66c
DAC	1	0.54 / 20	19	0.19	OFC	PE Foam	Cond. Nylon	Res. PVC	Ø6.1	43	45	110	0.78c
Eff-i		0.46 / 21	12	0.22	Ag pl. OFC	PE	Alu/Pet Foil		Ø7.2	68	38	75	0.66c

**EFF-ISL**

Analogue interconnect comprising PPSL connectors with clamping for improved contact.

Minimal skin-effect, very low capacitance, quick response. Suitable for CD/pre-amplifier/power amplifier. Correct transients, dynamics and sound stage.



**EFF-IX**

Analogue interconnect comprising PPX connectors.

Minimal skin-effect, very low capacitance, quick response. Suitable for CD/pre-amplifier/power amplifier. Correct transients, dynamics and sound stage.



**EFF-IXLR**

Balanced analogue interconnect comprising SWIFT XLR.

Minimal skin-effect, very low capacitance, quick response. Suitable for CD/pre-amplifier/power amplifier. Correct transients, dynamics and sound stage. Balanced for further improved noise rejection. Suitable for advanced home systems.



**EFF-IRB**

Analogue interconnect comprising PPR connectors.

Minimal skin-effect, very low capacitance, quick response. Suitable for CD/pre-amplifier/power amplifier. Depicts music with natural sound.

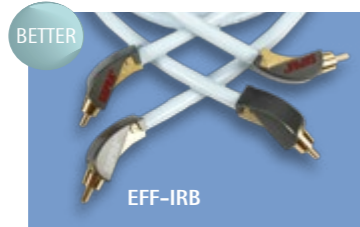

**Dual-RCA**

Analogue interconnect comprising RCA-6 connectors.

Low capacitance, active response. Suitable for CD/pre-amplifier/power amplifier. Test winning entry level cable closer to reality.



**DAC-SL**

Analogue interconnect comprising PPSL connectors with clamping for improved contact.

Low skin-effect, extremely low capacitance, exceptionally responsive. Suitable for CD/pre-amplifier/power amplifier. Depicts music with natural sound and very clean transients.



**DAC-X**

Analogue interconnect comprising PPX connectors.

Low skin-effect, extremely low capacitance, exceptionally responsive. Suitable for CD/pre-amplifier/power amplifier. Depicts music with natural sound and very clean transients.



**DAC-XLR**

Balanced analogue interconnect comprising SWIFT XLR.

Low skin-effect, extremely low capacitance, exceptionally responsive. Suitable for CD/pre-amplifier/power amplifier. Correct transients, dynamics and sound stage. Balanced for further improved noise rejection and are suitable for longer distance routing in e.g. studios, advanced home systems.



**6RCA-6RCA**

Analogue interconnect comprising RCA-3 connectors for multi channel e.g. SACD signal transmission. Minimal skin-effect, very low capacitance, quick response. Suitable for multi channel applications where player D/A converter is superior to e.g. A/V receiver. Depicts music with natural sound.



**SUPRA recommends:**

- EFF-XLR, DAC-XLR: Advanced home and studio systems
- EFF-ISL/-IX/-IRB, DAC-SL/-X: Intermediate up to advanced mid-end home systems
- Dual-RCA: Entry level up to intermediate home systems.

S U P R A | S w o r d



**Sword-1**

*For audiophiles who desire the full musical experience*

**The Design.**

The figure below illustrates the cable design. In each polarity there are twelve individually insulated strands forming two layers, the inner six spun with high pitch in one direction, the outer six in the opposite. This way of strand orientation, efficiently counteracts negative electrical interference giving all audible frequencies uniform transmission conditions and no open window for degrading noise to enter. The music will pass through sounding exactly the same. That is what distinguishes a really transparent cable.

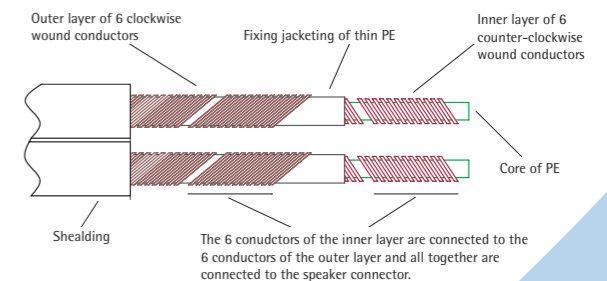

**Sword Interconnect Cables  
SUPRA SWORD-ISL RCA  
SUPRA SWORD-IXLR**

The Sword speaker cable success gave birth to an idea of an entire series based on the same technology. The SUPRA concept of signal technology based interconnects, with a minimalistic visual foot print, maintaining the signal integrity within the entire audible spectrum, immune to negative noise effects, at a price attractive to everyone, wouldn't that be the ultimate offer to our customers? We think so, hence Sword!

SUPRA Sword is also available as speaker cable. Refer to page 23 for further information.

**HiFi+ Editors Choice Award  
"Best Interconnect over £100"**

All SUPRA connectors provide for shielded metal covers and the cables are designed providing SUPRA highly efficient shielding. This results in low noise interconnects. Further, the cable is designed with low capacitance and high speed. This results in correct transients, dynamics, timing and 3D sound stage.

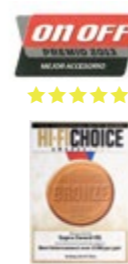

Item	Mechanical Specifications								Electrical Specifications				
	Cross. Area (mm <sup>2</sup> /AWG)	No. Cond.	Wires/Cond.	Wire/Wire dia. (mm)	Wire Material	Insulation	Screen Coverage	Jacket	Ext. Size (mm)	R (Ω/km)	C (nF/m)	Phase Disloc. 0.5-100kHz	Phase Error
Sword-1	1.5 / 15	2	6 + 6	0.4	Enameled OFC	PE	Alu/PET Foil, 100%	PVC Crystal	8	33	0,14	0.96 Deg.	0

# AV Series

## AV Series: Audio/Video cable, Multi-coax 75ohm

AV series comprise of individually shielded coaxial cables, hence the name multi-coax. Each true 75ohm coax has a tin plated braided screen and low capacitance thanks to foamed PE insulation. This design is especially suitable for home cinema applications and transmission of either high quality audio or video.

Suitable connectors: DB25, VGA, Scart, RCA, S-VHS, DVI-I and BNC.

The timing clearance is better than 2.2nanoseconds, making it very good for RGB transmissions.

Suitable applications:

- home cinema
- high definition video projection
- CG workstations
- studio wiring

The SUPRA AV-6.4 also consist of a twin pair audio cable as a core for the surrounding multi-coax.



### AV-2

AV-2 comprises two coax cables with a common screen foil.  
Typical application: S-VHS.  
Suitable connectors: SVHS-7 and Scart.  
S-video = Y/C.



### AV-3

AV-3 comprises three coax cables with a common screen foil.  
Typical application: component video, audio/video.  
Suitable connectors: Scart, RCA-3, BNC-3, DVI-I and VGA.  
Component video = Y/Cb/Cr.



### AV-4

AV-4 comprises four coax cables with a common screen foil.  
Typical application: RGB, component video, audio/video.  
Suitable connectors: Scart, RCA-3, BNC-3, DVI-I and VGA.



### AV-6.4

AV-6.4 comprises six coax cables with a common screen foil spun around a core of 2 pair audio cable with an individual shield.  
Typical application: RGB, S-VHS, component and composite video and audio.  
Suitable connectors: Scart, VGA, SVHS-7 and RCA-3.

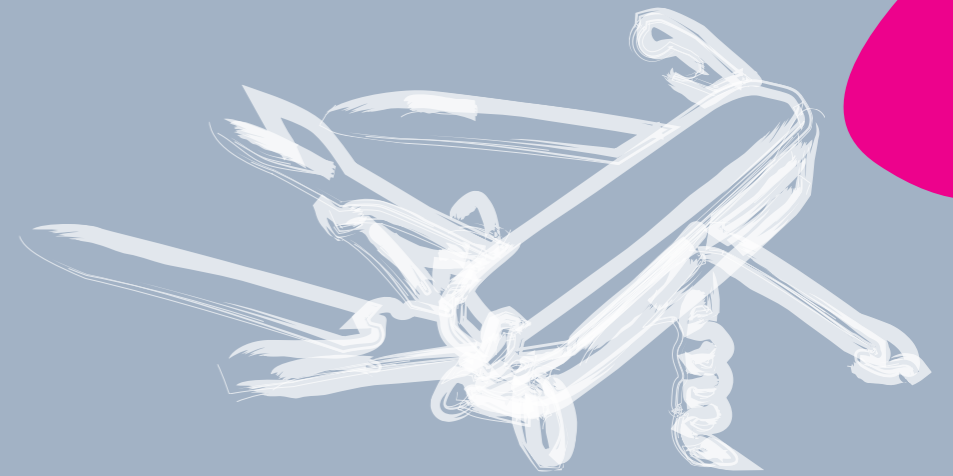

## SUPRA - Custom Order Cables



Inside the solder team dept. in Ljungskile, Sweden



All SUPRA cables are soldered by craftsmen certified up to military specifications.

Thanks to our flexible production, skilled craftsmen, all certified for military specification soldering, we can offer custom tailored cables from your own specification. Choose cable, length and connectors and we do the rest. Furthermore we can repair and/or alter your existing cables. Submit an inquiry at your local SUPRA dealership for price and technical review.

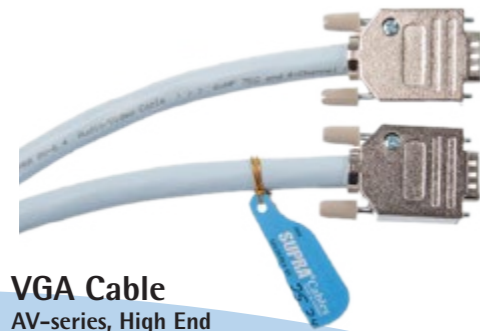

**VGA Cable**  
AV-series, High End

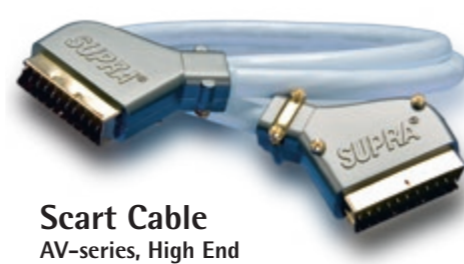

**Scart Cable**  
AV-series, High End

### VGA Cable and Scart Cable - AV Series, High end

These combined cables are especially made from the multi-coax, AV cable, featuring true 75ohm for correct impedance match and foam PE insulation for low losses and correct timing. It is utilized in many of our AV combination cables and available pre-terminated in a number of dedicated cables e.g. VGA, RCA, BNC, Scart and DVI, among others. Note type of signal or possible signal directionality in the table below.

- All individually shielded and true 75ohm
- Audio section is separately shielded for a minimum of cross-talk.
- Low capacitance thanks to foam PE insulation
- Common outer foil screen protects the entire cable from noise pick-up

Item	Mechanical Specifications											Electrical Specifications				
	Application Examples	No. of Coax	Cross. Area (mm <sup>2</sup> /AWG)	No. Wires	Wire Material	Insulation	In. Screen Coverage	Coax Jacket	Outer Screen Coverage	Jacket	Ext. Size (mm)	Weight (g/m)	R (Ω/km)	C (pF/m)	Imp. Z (Ω)	Velo. Factor
AV-2	S-video or AV	2	0,20 / 24	1	Tin Plated OFC	PE-Foam	Braid 120x0.10 OFC Sn >95%	Heat & Ageing Resistant	Al/Pet, 100%	Heat & Ageing Resistant	Ø7.0	53	87,8	45	75	0.78c
AV-3	Component / AV	3							-	Ø8.0	68					
AV-4	RGB or AV	4							Al/Pet	Ø9.5	105					
AV-6.4		6 (+4)							Foil, 100%	PVC	Ø11.0	147				

Attenuation: 1MHz/1.4 dB, 5MHz/3.1dB, 10MHz/4.4dB, 50MHz/9.8dB

Additional product information available in the final section

AV S-VIDEO SCART VGA

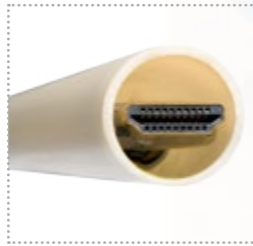

**HDMI MET S/B FRHF  
HDMI-DVI MET S/B FRHF**

High speed digital multimedia cable with removable connector housing allows for permanent in-wall installations in 20mm tubes or 25mm conduits. Available in 1-30meter lengths and both in PVC- and FRHF insulation.

**CLASSIC/H Speaker Cable**

High quality speaker cable with two tin plated, multi-strand, conductors. Made from 5N OF copper. Available area between 1.6 to 6mm<sup>2</sup> and both in PVC- and FRHF insulation.

**RONDO/H Speaker Cable**

High quality speaker cable with four tin plated, multi-strand, conductors, and high pitch twisted for noise cancellation. Made from 5N OF copper. Available area between 1.6 to 6mm<sup>2</sup> and both in PVC- and FRHF insulation.

**CAT7+ FRHF Network Cable**

Very fast, high quality network cable, available pre-terminated with RJ45 connectors or bulk and with FRHF insulation.

**DVI FRHF**

Single-link or dual-link DVI cable available both as PVC- and FRHF insulated and pre-terminated with shielded aluminium housing connectors. 1-20meter lengths.

**MB/H Series Installation**

Balanced Microphone and Line cable. one, two or four pair configuration with individual shield and jacket for each pair. Refer to page 47 for additional information. Suitable for: Permanent installation, balanced wiring e.g. studios, stages and so on.

## We deliver!

*SUPRA have developed a number of permanent installation products for both home and public applications.*

*FRHF Series is halogen free and flame retardant and has earned an E-number for the European market.*





### MBS Microphone Cable ■ On-stage, in studios

A no-compromise design, both mechanically and electrically. Negligible microphony, high noise rejection, low capacitance, high flexibility, high bending strength. The best microphone and instrument cable for professionals.

Balanced two pair cable with individual shields and jackets.

Typical applications: permanent installation, balanced wiring



### MB Multi-series ■ Permanent installations

A no-compromise design, both mechanically and electrically. Negligible microphony, high noise rejection, low capacitance.

The jacket insulation is thinner and shield is an aluminium screen to suit permanent installations.



### CUEFLEX DMX512 ■ Control Cable

The standard DMX512-A has provided for this cable design suitable for lights control, CAN Bus and digital AES/EBU (EAS3). Its characteristics is very low capacitance, true 120ohm, double shielded, yet flexible. The applications are countless, but aimed for pro-stage and studio.



### MB-01/H Installation ■ Mic/Line cable Balanced

Single pair, shielded for permanent installation



### MB-02/H Installation ■ Mic/Line cable Balanced

Two pair, individual shield and jacket for permanent installation



### MB-04/H Installation ■ Mic/Line cable Balanced

Four pair, individual shield and jacket for permanent installation



### MB-08 Installation ■ Mic/Line cable Balanced

Eight pair, individual shield and jacket for permanent installation

Item	Mechanical Specifications											Electrical Specifications					
	No. pair	Application Examples	Cross. Area (mm <sup>2</sup> /AWG)	No. of Cond./Pair	No. Wires	Wire Dia. (mm)	Wire Material	Insulation	Screen	Tensile Re-inforcem.	Jacket	Temp. Range (°C)	Weight (g/m)	R (Ω/km)	C (pF/m)	Imp. Z (Ω)	Velo. Factor
MBS	1	Mic./Line	0.24 / 23	2 +	19	0,127	Tin plated OFC	PE	Cond. Nylon	Polyester	Heat & Res. PVC	-20 to +90	34	72	52	70	0.66c
CueFlex	1	DMX512	0.24 / 23	2 + Drain Wire	19	0,127	Tin plated OFC	PE Foam	Alu/PET+Braid	Polyester	Heat & Res. PVC	-20 to +90	56	72	32	110	0.78c

Item	Mechanical Specifications													Elec. Spec.			
	No. of Pairs	Application Examples	Cross. Area (mm <sup>2</sup> /AWG)	No. Wires	Wire Dia. (mm)	Wire Material	Insulation	No. of Cond.	Drag-armoring	Screen	Pair-Jacket	Jacket	Temp.-Rge (°C)	Ext. Size (mm)	Weight (g/m)	R (Ω/km)	C (pF/m)
MB-01/H	1	Analogue	0.24 / 23	19 pcs / Cond.	0,127	Tin-Plated OFC	PE	2	-	Alu/PET Foil	PE	FRHF	-20 to +90	Ø4.8	32	72	52
MB-02/H	2	Audio		+				Polyester/Silk Yarn	Ø7.0					42			
MB-04/H	4	Mic./Line		Drain Wire				Ø8.0	72								
MB-08	8	Installation		PVC				Ø10.8	130								





## Selected Awards and Reviews

Product	Review/Award	Source	Year	Country
Quadrax Speaker Cable, Danish	Review	www.hifi4all.dk	2012	Denmark
Quadrax Speaker Cable, English	Review	www.hifi4all.dk	2012	Denmark
HDMI Met-S/B Cable	Gold Award	on OFF	2012	Spain
USB Cable	★★★★★	What Hi-Fi	2012	UK
Sword-isl	★★★★★	on OFF	2012	Spain
EFF-IRB	Review	What Hi-Fi	2012	Russia
Ply 3.4 Et Rondo 2x2.5	Review	Stereo	2011	Russia
HDMI-HDMI Met-S/B	Review	What Hi-Fi	2011	Russia
Ply Speaker Cable	Outstanding Product	Hi-Fi News	2010	UK
Mains Block MD06-BS/SP	★★★★★	Hi-Fi Choice	2009	UK
Mains Block MD06-BS/SP	Highly Commended	Hi-Fi News	2009	UK
Mains Block MD06-EU/SP	Test	Haute Fidélité	2009	France
Sword-ISL Interconnect	Highly Commended	Hi-Fi News	2009	UK
Sword-ISL Interconnect	Bronze Award	Hi-Fi Choice	2009	UK
HF100 HDMI Cable	★★★★★	What Hi-Fi	2008	UK
EFF-IX Interconnect	Silver Award	Hi-Fi Choice	2008	UK
AnCo Digital Interconnect	Best Buy	Hi-Fi Choice	2008	UK
EFF-IX Interconnect	Best Buy	Hi-Fi Choice	2008	UK
HF100 HDMI Cable	★★★★★	What Video	2007	UK
Mains Block MD06-BS/SP	★★★★★	What Hi-Fi	2007	UK
HF100 HDMI Cable	Review	AV Review	2007	UK
EFF-IX Interconnect	★★★★★	What Hi-Fi	2007	UK
Dual Interconnect	★★★★★	What Hi-Fi	2007	UK
Rondo 2x2.5	★★★★★	What Hi-Fi	2007	UK
AnCo Component Cable	★★★★★	What Hi-Fi	2007	UK
EFF-IX Interconnect	★★★★★	What Hi-Fi	2007	UK
EFF and Dual Interconnects	★★★★★	What Hi-Fi	2007	UK
Sword-ISL	Test	Hi-Fi World	2007	UK
Sword-ISL Editor's Choice	Test	Hi-Fi Choice	2007	UK
Scart AV6.4 Cable	★★★★	Active Home	2007	UK
HF100 HDMI Cable	★★★★★	Active Home	2007	UK
AnCo Component	★★★★★	Active Home	2007	UK
Sword Cables	Test	Hi-Fi Plus	2007	UK
Sword Cables 123	Test	Internet	2007	Holland
Mains Block MD06-EU/SP	Test	Stereo	2006	Germany
Sword Interconnects	Review	Stereo	2006	Germany
Sword-ISL Interconnect	Test	Bild & Ljud Hemma	2006	Sweden
HF100 HDMI Cable	Test	HIVI	2006	Japan
SUPRA Factory	Article	HIVI	2006	Japan
LoRad Mains Cord Set	Test	Hi-fi Choice	2006	UK
HDMI HF100	News	What Hi-Fi	2006	UK
Sword Speaker Cable	Test	Hi-Fi+	2006	UK
FS_Scart_Cable	Test	The Independent	2006	UK
Billine MP-RCA	Test	Mac Format	2006	UK
Anco Component Video	Test	What Hi-Fi	2006	UK
Sword-isl Interconnect	Test	Hi-Fi & Musik	2006	Sweden
Sword Jumper	Review	Stereo	2006	Germany
FS_Scart_Cable	Test	What Hi-Fi	2005	UK
FS_Scart_Cable	Test	Home Cinema	2005	UK
LoRad Cord Set	Test	What Hi-Fi	2005	UK
HF100 HDMI Cable	Test	Home Cinema	2005	UK
Sword 3.0 Speaker Cable	Test	Hi-Fi +	2005	UK
SUPRA Factory	Article	Stereo	2004	Germany
Sword 3.0 Speaker Cable	Test	Alta Fidelidad	2004	Spain
Sword 3.0 Speaker Cable	Test	www.tnt-audio.com	2003	Internet
Eff, Trico Et Sword	Multi Test	Stereo	2003	Germany
Rondo 4x2.5 Speaker Cable	Test	www.tnt-audio.com	2003	Internet
Trico-RCA Video/Digital Cable	★★★★★	Hi-fi Choice	5/2003	England
AV-3 Component Cable	★★★★★	What Hi-fi	10/2002	England
X-Zac Fiber Optic Cable	★★★★★	What Hi-fi	9/2002	England
Rondo 4x2.5 Speaker Cable	★★★★★	What Hi-fi	9/2002	England
Scart RGB Cable	★★★★★	What Hi-fi	4/2002	England
EFF-ISL and Screened PLY 3.4	Test	Stereo Times	2001	U.S.A
Classic 4.0 speaker cable	Best Buy	What Video Et TV	4/2000	England
PLY 3.4/S Speaker cable	Review	www.tnt-audio.com	1999	www
EFF-ISL Interconnect	Best Buy	Hi-Fi Choice	3/1999	England

LATEST NEWS! SUPRA FLAT



Can be taped to the wall with Supra's double-sided adhesive tape

## SUPRA Flat - Super flat speaker cable

### SUPRA Flat 1.6

White 2x1.6sqmm  
A super flat speaker cable, only 1.95mm thick and 11.7mm wide.  
Ideal for unobtrusive wiring on wall or under carpet.  
Can be taped to the wall with Supra's double-sided adhesive tape.

The conductors consists of compressed tin plated OFC braid. The special manufacturing process makes the cable both super flat and highly flexible. The tin plated Copper contributes to a better sound quality by minimising the skin-effect and making less current jumps between the wire surfaces.

#### Advantages

- Unobtrusive wiring on wall and under carpet
- No special installation tools required
- Easy to strip
- Flexible design for easy routing in corners and around doorframes
- Easy connection. No connectors are required
- Paintable insulation
- Can be taped to the wall with Supra's double-sided adhesive tape
- Tin plated conductors provides excellent corrosion resistance
- Made in Sweden

Product	Mechanical Specifications							Electr. Spec.		Sales Info			
	Cross. Area (mm <sup>2</sup> /AWG)	No. Cond.	No. Wires	Wire Dia. (mm)	Wire Material	Jacket	Ext. Size (mm)	Weight (g/m)	Tape Incl.	R (Ω/km)	L (μH/m)	E-No	Item No
FLAT 1.6 WHT B200	1.6 / 15	2	96	0.15	Tin Plated OFC	Heat & Ageing Res. PVC	1.95	54	10m	10.8	0,36	4800053	1000000925
FLAT 1.6 WHT 10M							10m		1000000933				
FLAT 1.6 WHT 20M							20m		1000000941				

You will find all our awards Et rewards on our homepage [www.jenving.se](http://www.jenving.se)

**SUPRA<sup>®</sup> Cables**  
MADE IN SWEDEN  
by JENNING TECHNOLOGY

Bastebacka 112-113  
SE-459 91 Ljungskile  
SWEDEN



Telephone: +46 (0)522-69 89 90  
Telefax : +46 (0)522-69 89 99  
E-mail : [supra@jenving.se](mailto:supra@jenving.se)



[www.jenving.se](http://www.jenving.se)